

RE-BID USCA PACER DOWNS FIRE ALARM REPLACEMENT PROJECT NUMBER FP00000284

ELECTRICAL SHEET LIST

- E000 – COVER SHEET
- E002 – ELECTRICAL SITE PLAN
- E003 – TYPICAL DEMOLITION FIRE ALARM PLAN
- E004 – TYPICAL DEMOLITION FIRE ALARM PLAN
- E005 – TYPICAL DEMOLITION FIRE ALARM PLAN
- E501 – TYPICAL NEW FIRE ALARM PLAN
- E502 – TYPICAL NEW FIRE ALARM PLAN
- E503 – TYPICAL NEW FIRE ALARM PLAN
- E504 – FIRE ALARM NOTES AND DETAILS
- E505 – FIRE ALARM SYSTEM DIAGRAM

NO.	REVISION	DATE	BY

sims group
 SIMS GROUP ENGINEERS, INC.
 800 Columbian Drive, Suite 208
 Irmo, South Carolina 29963
 www.simsgrupos.com Fax: (803) 765-1030

BID SET

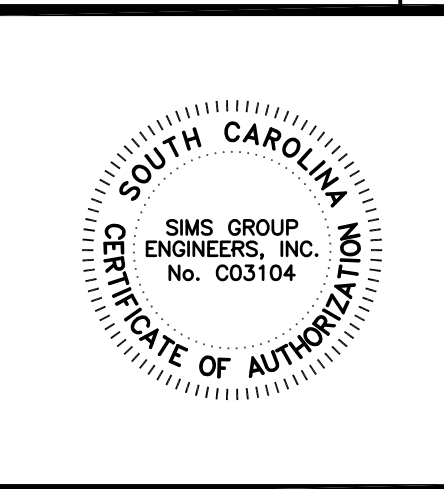

**RE-BID USCA PACER DOWNS FIRE
ALARM REPLACEMENT
PROJECT NUMBER FP00000284**

COVER SHEET

DRAWN	JMO
CHECKED	BLM
SIMS PROJECT No.	C19035
DATE	01.24.20

E000

DRAWING No. 1 OF 10

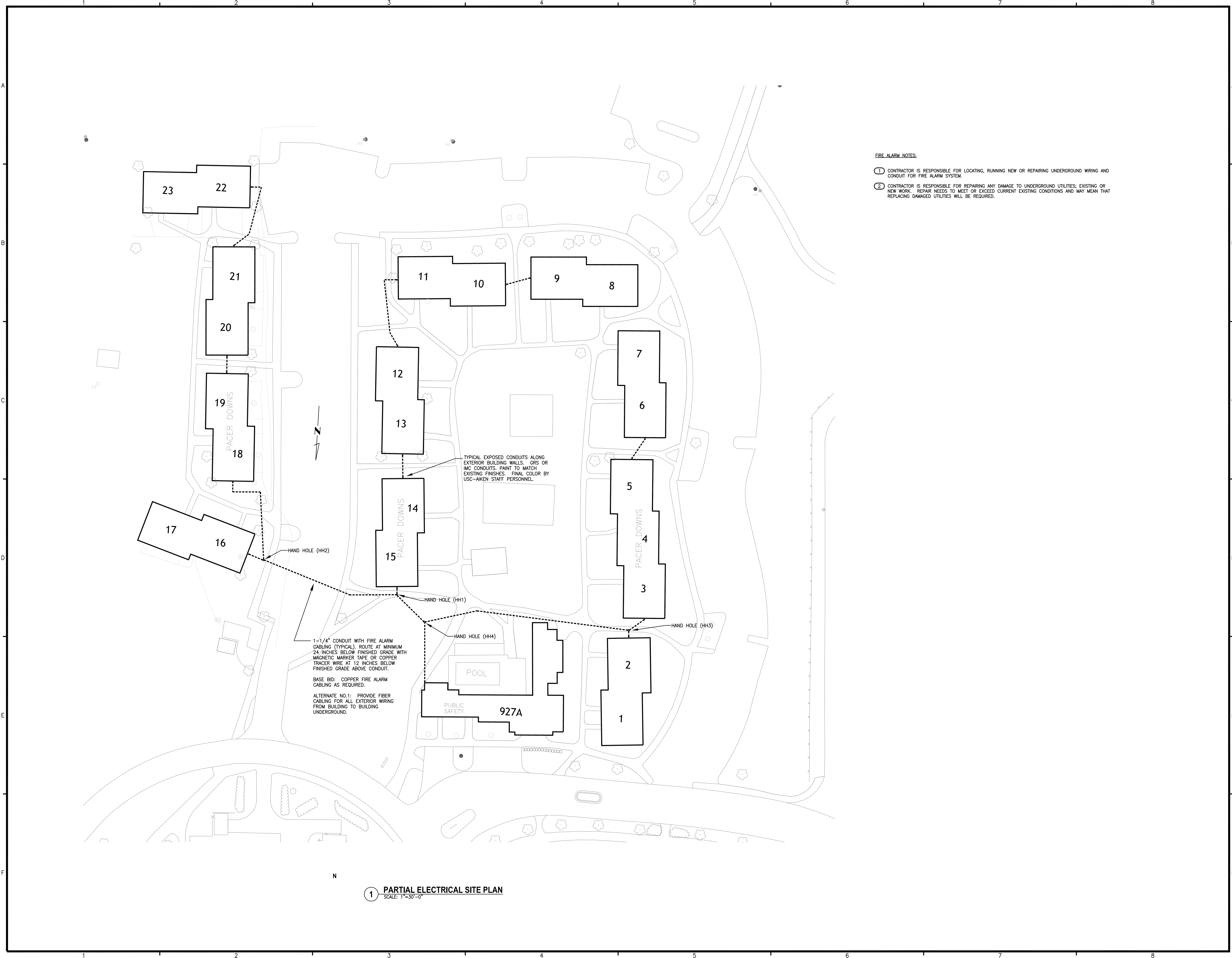

NO.	REVISION	DATE	BY
1			
2			
3			
4			
5			

sims group
 SIMS GROUP ENGINEERS, INC.
 800 Columbian Drive, Suite 208
 Iino, South Carolina 29663
 www.simsgrupos.com

BID SET

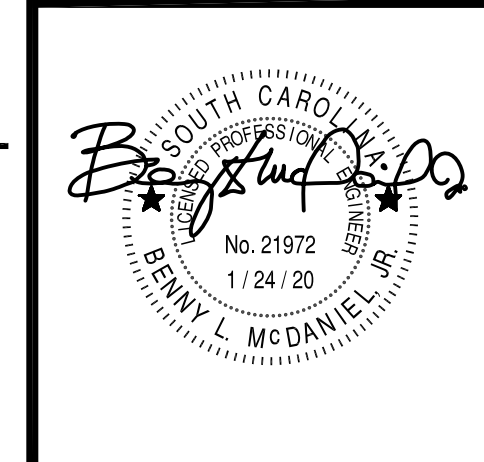
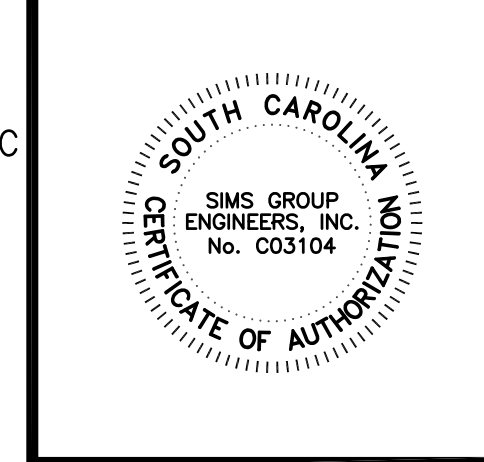

RE-BID USCA PACER DOWNS FIRE ALARM REPLACEMENT PROJECT NUMBER FP00000284

ELECTRICAL SITE PLAN

DRAWN	JMO
CHECKED	BLM
SIMS PROJECT No.	C19035
DATE	01.24.20

E002

DRAWING No. 2 OF 10

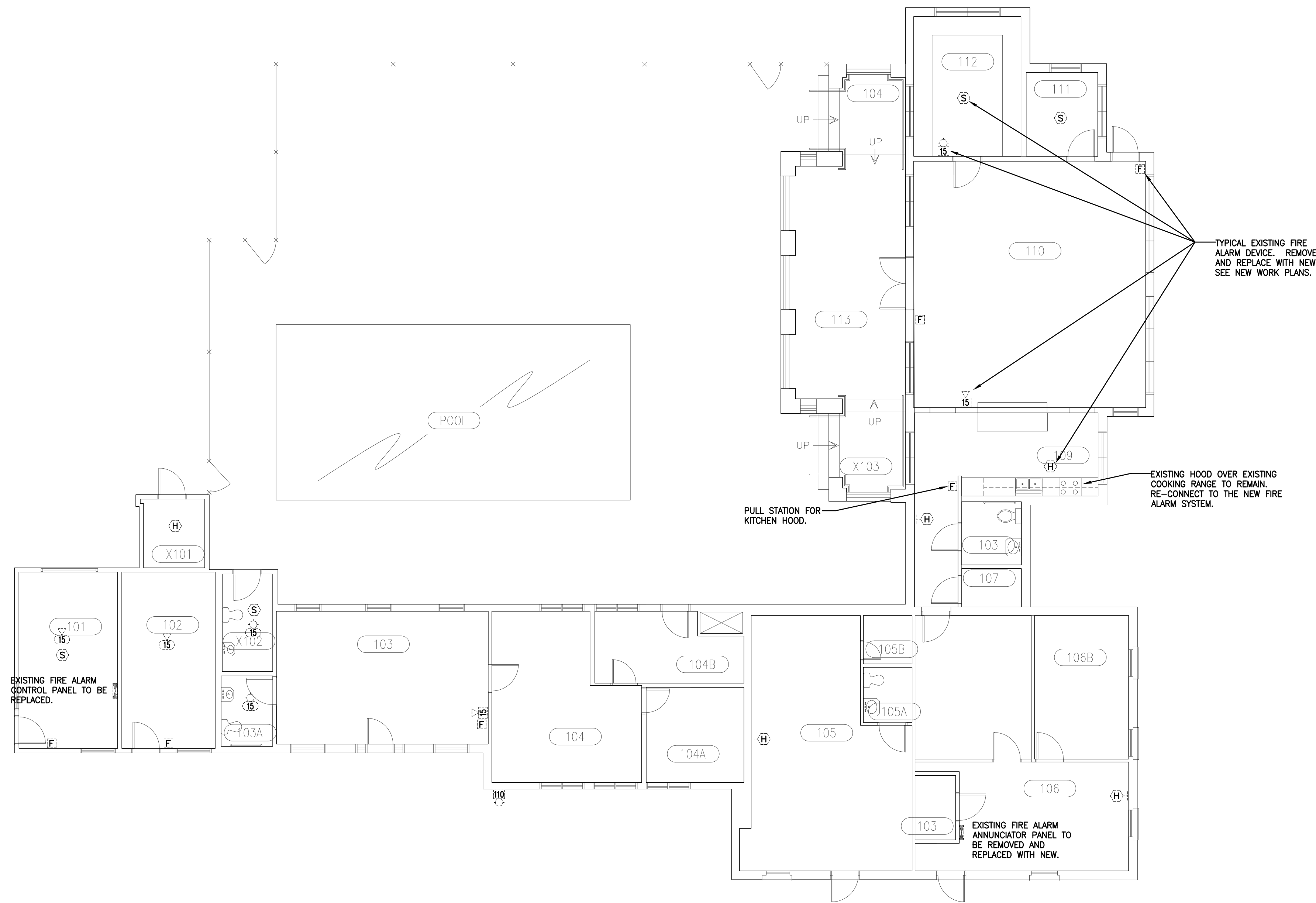

1 FIRST FLOOR PLAN - 927A
SCALE: 1/8"=1'-0"

ELECTRICAL DEMOLITION NOTES

- A. IT IS THE GENERAL INTENTION OF THESE DRAWINGS TO COVER ALL SITUATIONS WHERE AN ITEM IS TO BE REMOVED, WHETHER IT HAPPENS TO BE A SMOKE DETECTOR, HORN/STROBE, OR OTHER FIRE ALARM DEVICE, DUPLEX RECEPTACLE, LIGHT SWITCH, OR OTHER ELECTRICAL ITEM. THE ELECTRICAL CONTRACTOR SHALL ASSIST THE OWNER AND/OR GENERAL CONTRACTOR IN REMOVAL OF EQUIPMENT WITH ELECTRICAL CONNECTIONS BEING REMOVED BY THESE CONTRACTORS.
- B. PRIOR TO SUBMITTING BID, THE CONTRACTOR SHALL SURVEY THE EXISTING BUILDING AND MAKE NOTE OF ANY ADDITIONAL DEMOLITION AND/OR ANY ADDITIONAL REMOVAL AND RELOCATION WHICH MAY BE REQUIRED IN ORDER TO ACCOMPLISH RENOVATIONS INDICATED IN CONTRACT DOCUMENTS. NO CHANGE ORDER WILL BE ISSUED FOR ADDITIONAL WORK REQUIRED FOR DEMOLITION, REMOVAL, OR RELOCATION WORK NOT INDICATED ON THESE DRAWINGS BUT NECESSARY TO COMPLETE WORK.
- C. EXISTING CONDUIT RUN CONCEALED IN EXISTING WALLS NOT BEING REMOVED AND/OR REPLACED MAY BE ABANDONED. ALL DEMOLITION MUST BE COORDINATED WITH THE ENGINEER, USC-AIKEN PERSONNEL AND WITH ALL OTHER TRADES TO AVOID CONFLICTS.
- D. NO EXISTING ELECTRICAL MATERIALS, EQUIPMENT, WIRING, OR CONDUIT BEING REMOVED MAY BE REUSED ON THIS PROJECT UNLESS SPECIFICALLY NOTED OTHERWISE ON THESE DRAWINGS. TURN OVER ALL EXISTING ELECTRICAL MATERIALS AND EQUIPMENT TO THE OWNER (USC-AIKEN PERSONNEL).

FIRE ALARM EXISTING DEVICE LEGEND AND NOTES:

1. PHASING WORK TO BE PHASED AND PERFORMED SO THAT IT DOES NOT INTERFERE WITH THE NORMAL OPERATION OF THE SCHOOL AND CAMPUS HOUSING FOR STUDENTS. DEMOLITION AND INSTALLATION PHASING ARE TO BE CLOSELY COORDINATED WITH USC-AIKEN CAMPUS PERSONNEL. COORDINATE PHASING AND SCHEDULE WITH OWNER AND ENGINEER AT PRE-CONSTRUCTION MEETING PRIOR TO STARTING WORK. SUBMIT A WRITTEN PHASING PLAN AND SCHEDULE TO THE OWNER AND ENGINEER FOR REVIEW PRIOR TO STARTING WORK.
2. EXISTING FIRE ALARM CONTROL PANEL(S) AND FIRE ALARM ANNUNCIATOR(S), INCLUDING ANY NOT INDICATED ON THESE DRAWINGS, TO REMAIN DURING CONSTRUCTION AND TO BE REMOVED COMPLETE AFTER ACCEPTANCE OF NEW FIRE ALARM SYSTEM. MAINTAIN EXISTING WIRING, ETC. AS REQUIRED TO MAINTAIN OPERATION OF THE FIRE ALARM SYSTEM DURING CONSTRUCTION.
3. EXISTING SMOKE AND HEAT DETECTORS TO REMAIN DURING CONSTRUCTION, TO BE REMOVED COMPLETE AFTER ACCEPTANCE OF NEW FIRE ALARM SYSTEM.
4. EXISTING FIRE ALARM DUCT/IPDACT TO REMAIN DURING CONSTRUCTION, TO BE REMOVED COMPLETE AFTER ACCEPTANCE OF NEW FIRE ALARM SYSTEM.
5. EXISTING MONITORING MODULES TO REMAIN DURING CONSTRUCTION, TO BE REMOVED COMPLETE AFTER ACCEPTANCE OF NEW FIRE ALARM SYSTEM.
6. EXISTING MANUAL PULL STATIONS TO REMAIN DURING CONSTRUCTION, TO BE REMOVED COMPLETE AFTER ACCEPTANCE OF NEW FIRE ALARM SYSTEM.
7. EXISTING DUCT MOUNTED SMOKE DETECTORS AND ASSOCIATED KEY SWITCHES AND CONTROL MODULES TO REMAIN DURING CONSTRUCTION, TO BE REMOVED COMPLETE AFTER ACCEPTANCE OF NEW FIRE ALARM SYSTEM.
8. EXISTING NOTIFICATION APPLIANCES (HORNS AND HORN/STROBES) TO REMAIN DURING CONSTRUCTION, TO BE REMOVED COMPLETE AFTER ACCEPTANCE OF NEW FIRE ALARM SYSTEM.
9. REMOVE EXISTING OUTLET BOXES ASSOCIATED WITH THE EXISTING FIRE ALARM SYSTEM. CUT, PATCH, AND PAINT TO MATCH EXISTING. NEW PAINT COLOR SHALL MATCH ADJACENT FINISHES.
10. GENERAL NOTE: THE EXISTING FIRE ALARM SYSTEM IS TO REMAIN IN OPERATION DURING INSTALLATION OF NEW FIRE ALARM SYSTEM, TO BE REMOVED COMPLETE AFTER ACCEPTANCE OF NEW FIRE ALARM SYSTEM.
11. GENERAL NOTE: EXISTING FIRE ALARM DEVICES ARE SHOWN FOR INFORMATION PURPOSES ONLY AND ARE NOT INTENDED TO REFLECT ALL EXISTING DEVICES INSTALLED. DEVICES INDICATED ARE BASED ON AVAILABLE RECORD DRAWINGS AND A SITE VISIT PERFORMED BY SIMS GROUP ENGINEERS, INC. THE CONTRACTOR IS RESPONSIBLE FOR REMOVAL OF ALL EXISTING FIRE ALARM DEVICES, WITHIN THIS SCOPE OF WORK, AND ASSOCIATED WIRING AND CONDUIT NO LONGER IN USE WHETHER OR NOT THE DEVICES ARE INDICATED ON THESE PLANS. REFER TO ADDITIONAL DEMOLITION NOTES.
12. CEILING MOUNTED NOTIFICATION DEVICES: IN SPACES WITH ACCESSIBLE LAY-IN CEILINGS LESS THAN 20' AFF WHERE WALL MOUNTED NOTIFICATION APPLIANCES ARE INDICATED, CEILING MOUNTED NOTIFICATION DEVICES MAY BE USED IN LIEU OF WALL MOUNTED PROVIDED COMPARABLE CODE-COMPLIANT STROBE AND HORN COVERAGE IS PROVIDED AND THE CHANGES ARE PROPERLY NOTED ON THE RECORD DOCUMENTS.

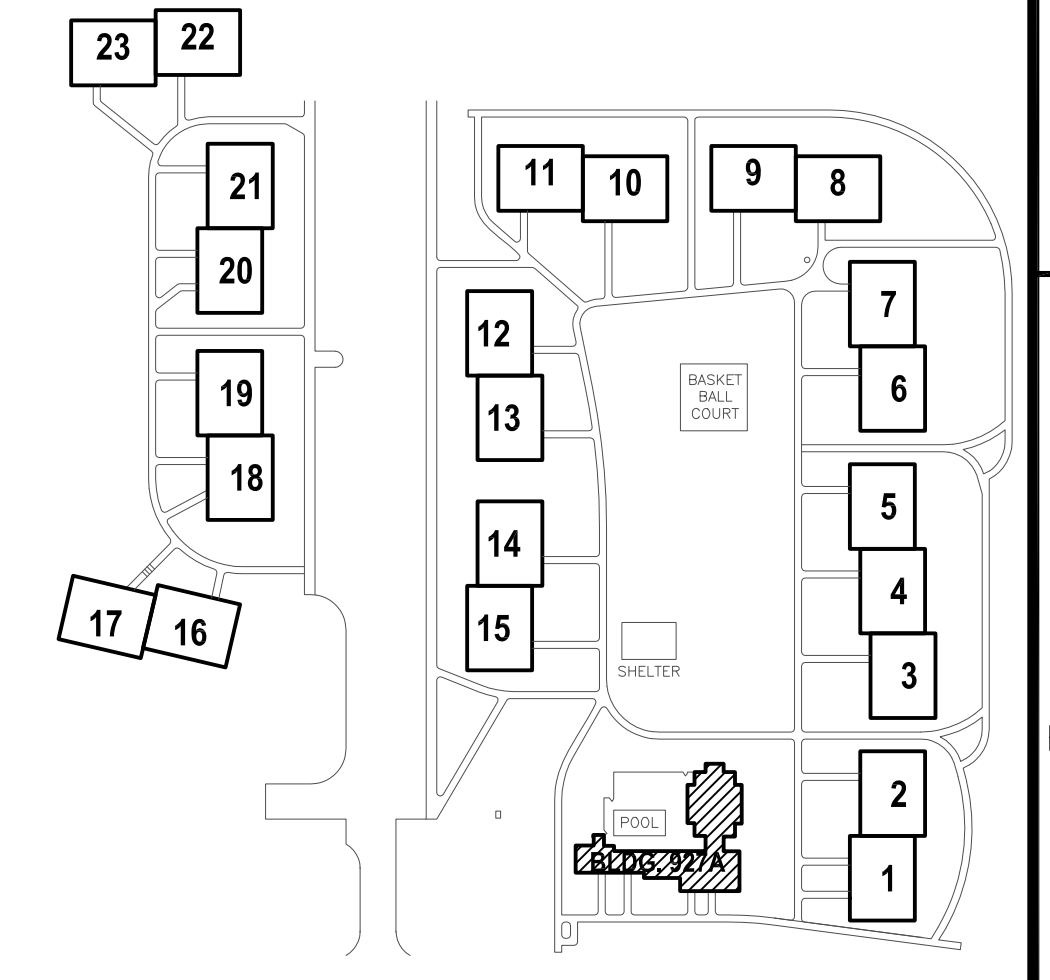

KEY PLAN
NOT TO SCALE

NO.	REVISION	DATE	BY

BID SET

sims group
SIMS GROUP ENGINEERS, INC.
800 Columbian Drive, Suite 208
Irvine, South Carolina 29663
www.simsgrupos.com

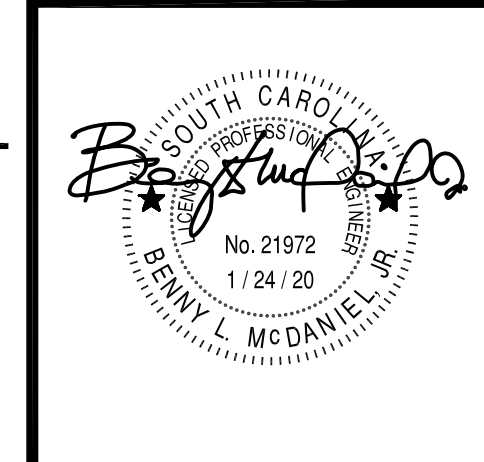
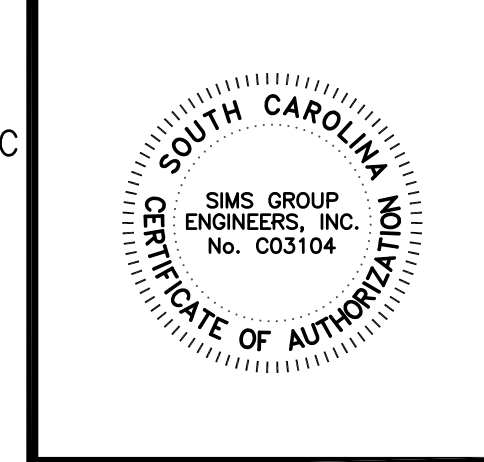

RE-BID USCA PACER DOWNS FIRE ALARM REPLACEMENT PROJECT NUMBER FP00000284

TYPICAL BUILDING DEMOLITION FIRE ALARM PLAN

DRAWN	JMO
CHECKED	BLM
SIMS PROJECT No.	C19035
DATE	01.24.20

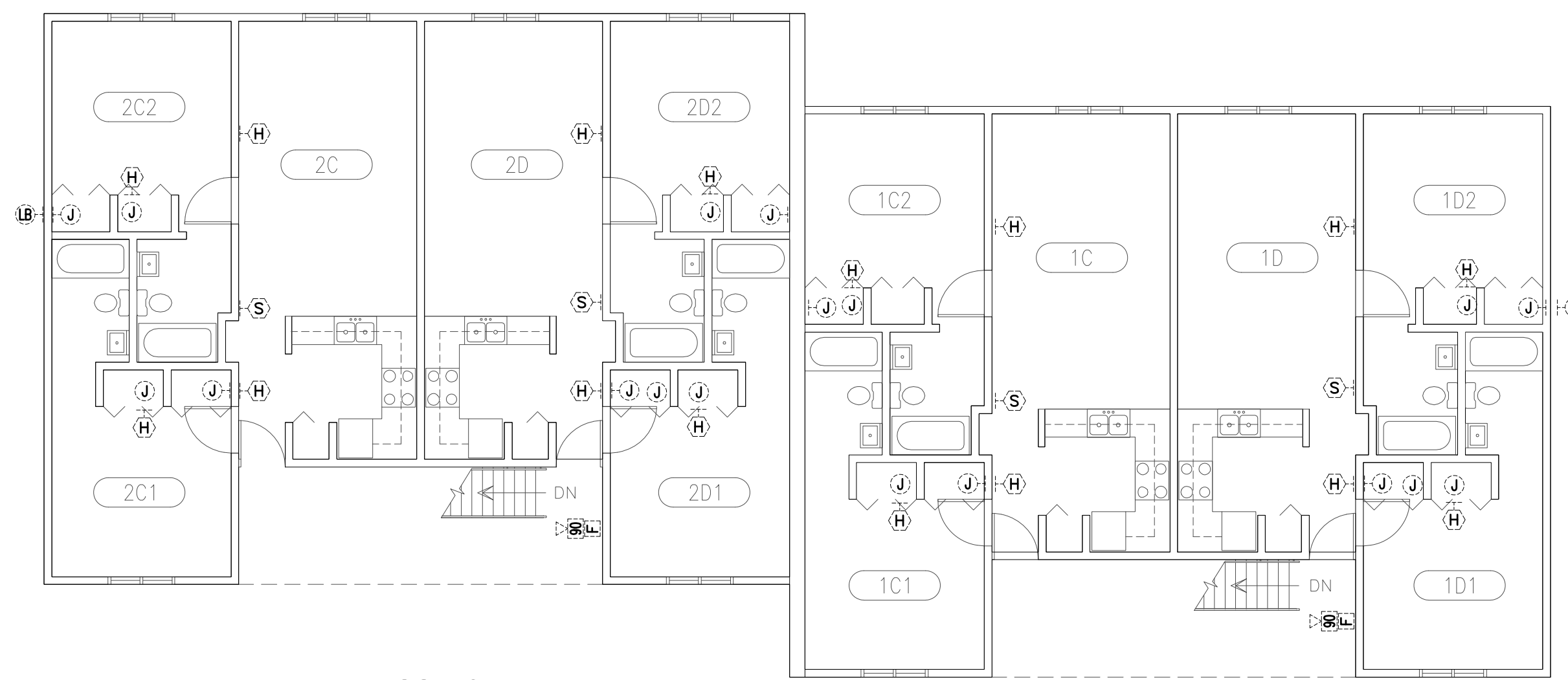

2 BUILDINGS 1 & 2
SECOND FLOOR PLAN
SCALE: 1/8"=1'-0"

***TYPICAL FOR ALL 8 UNIT APARTMENTS.

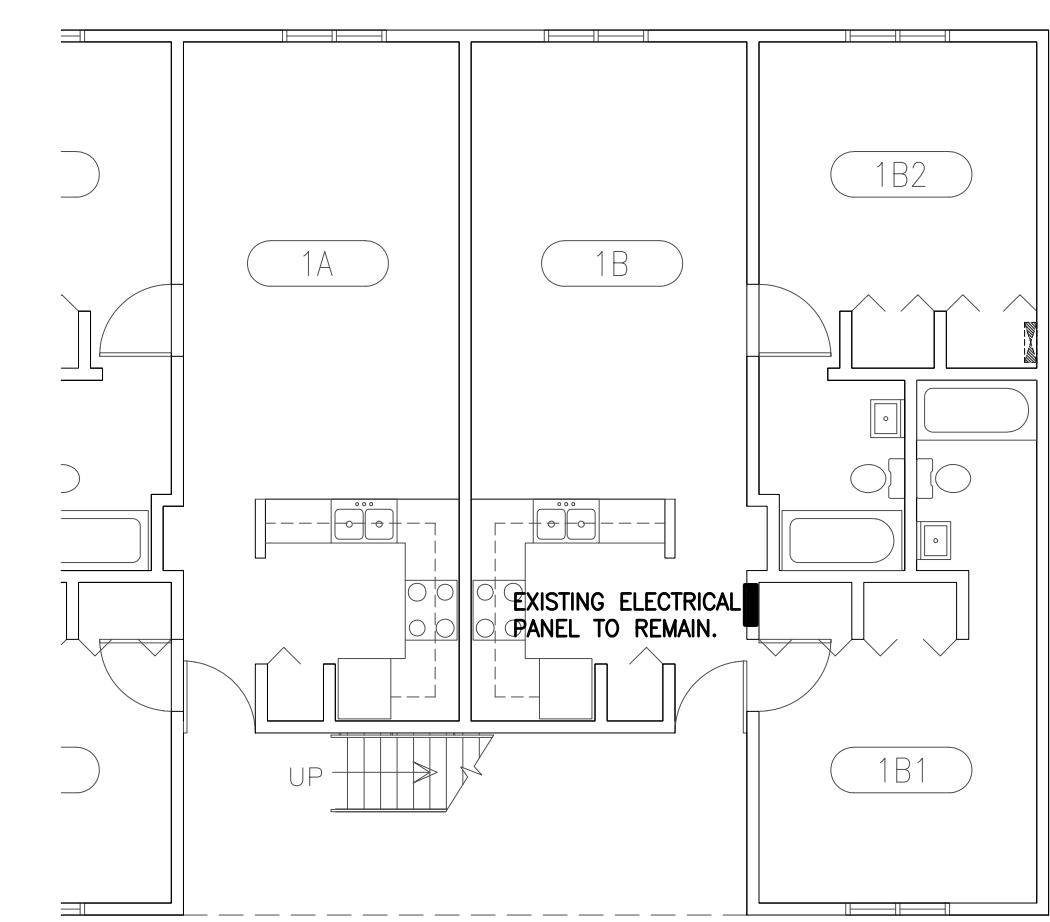

3 POWER PLAN
TYPICAL OF ALL UNITS
SCALE: 1/8"=1'-0"

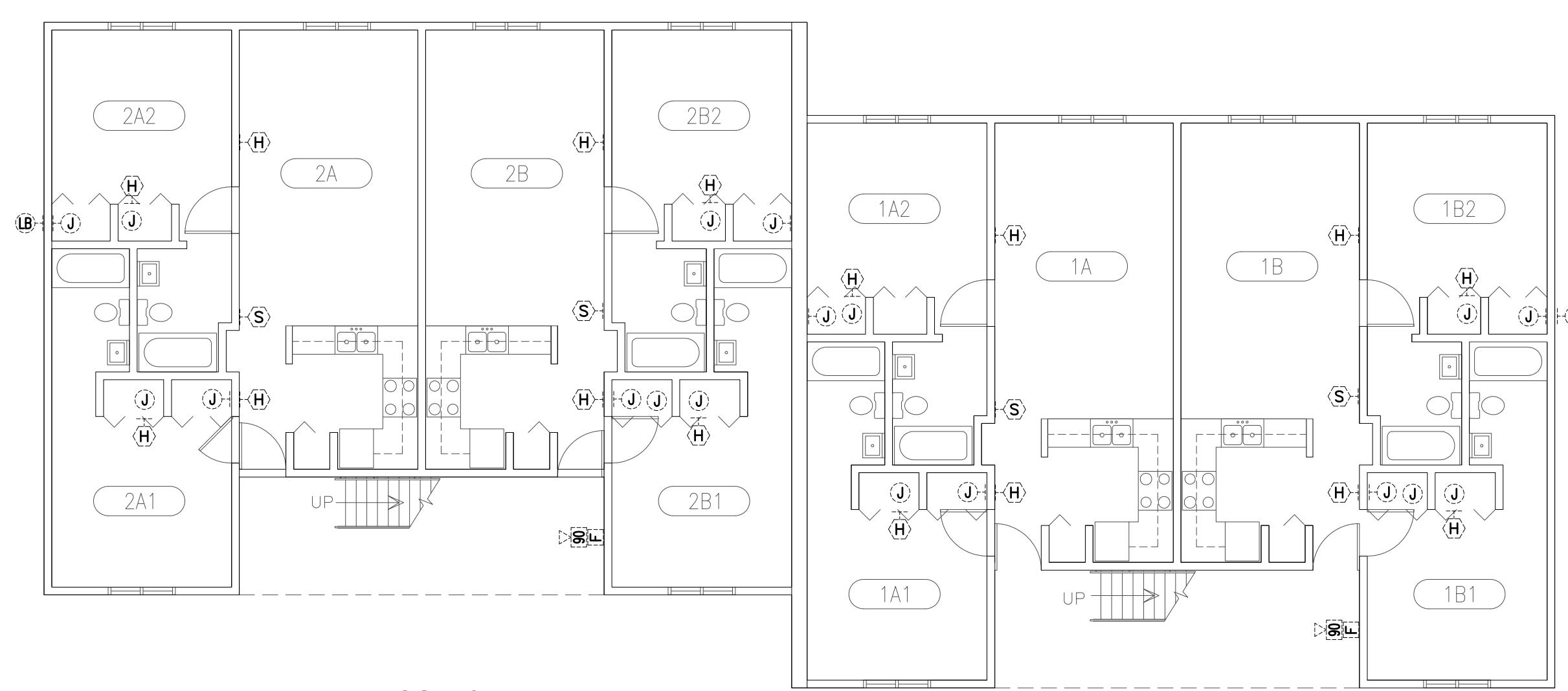

1 BUILDINGS 1 & 2
FIRST FLOOR PLAN
SCALE: 1/8"=1'-0"

***TYPICAL FOR ALL 8 UNIT APARTMENTS.

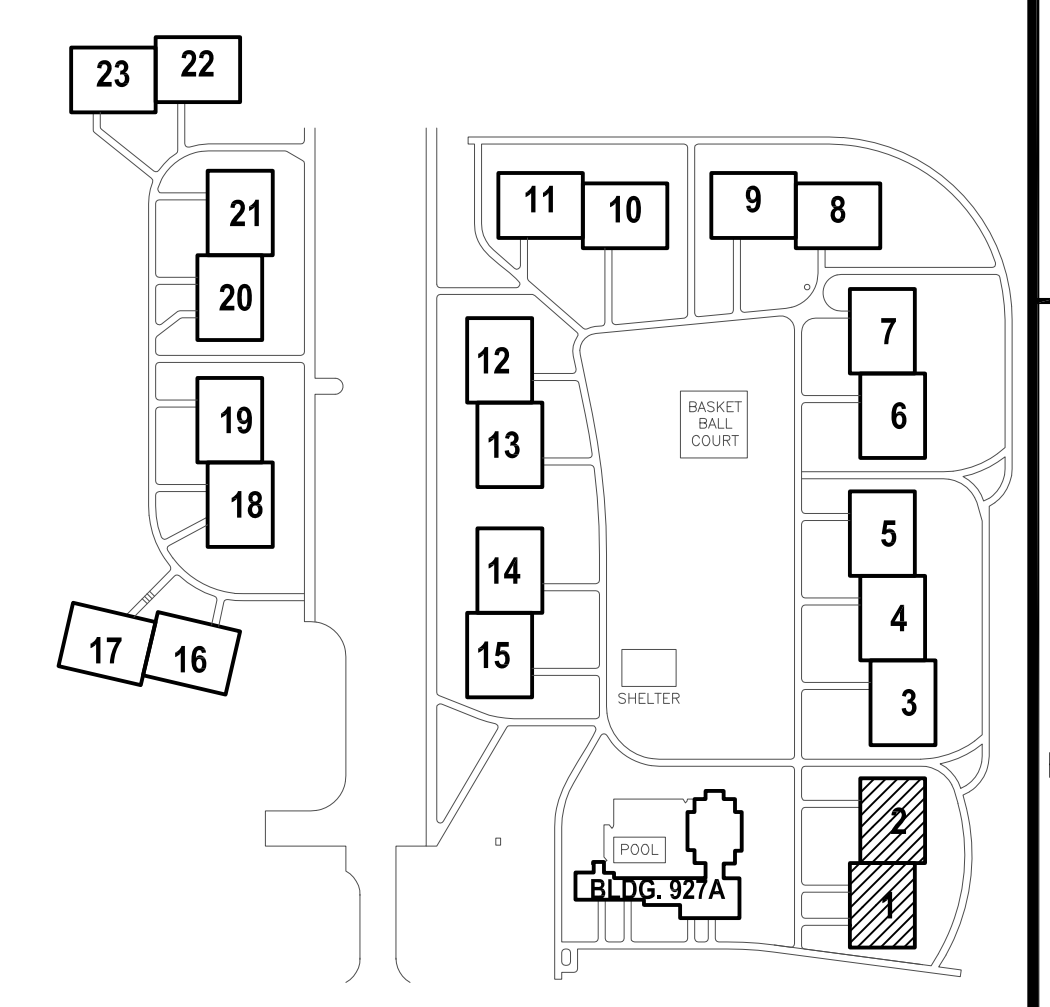

KEY PLAN
NOT TO SCALE

NO.	REVISION	DATE	BY
Δ			
Δ			
Δ			
Δ			

sims group
SIMS GROUP ENGINEERS, INC.
800 Columbian Drive, Suite 208
Irvine, South Carolina 29613
www.simsgrupos.com

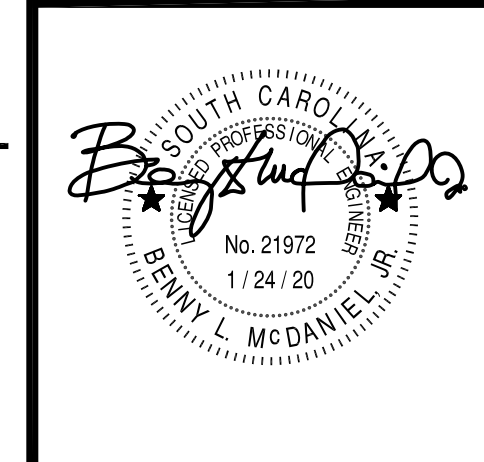
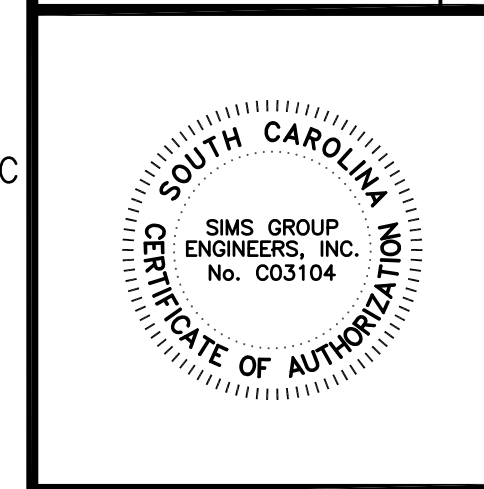

**RE-BID USCA PACER DOWNS FIRE
ALARM REPLACEMENT
PROJECT NUMBER FP00000284**

TYPICAL BUILDING DEMOLITION FIRE ALARM PLAN

DRAWN	JMO
CHECKED	BLM
SIMS PROJECT No.	C19035
DATE	01.24.20

E004
DRAWING No. 4 OF 10

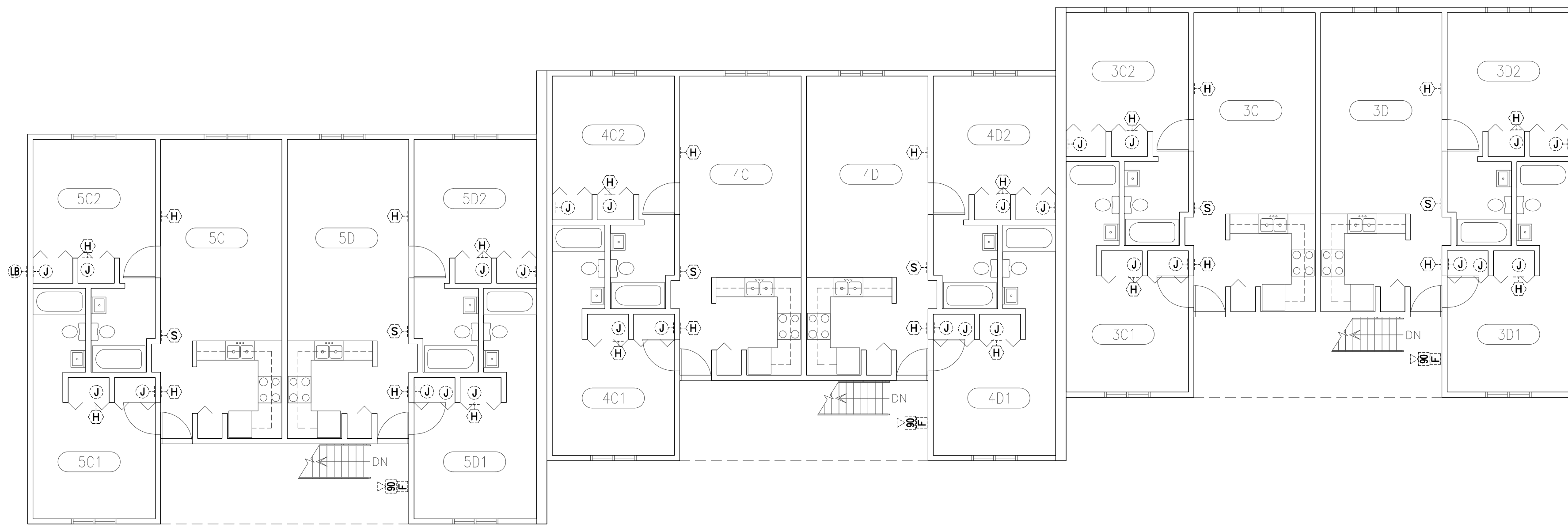

2 BUILDINGS 3, 4 & 5
SECOND FLOOR PLAN
SCALE: 1/8"=1'-0"

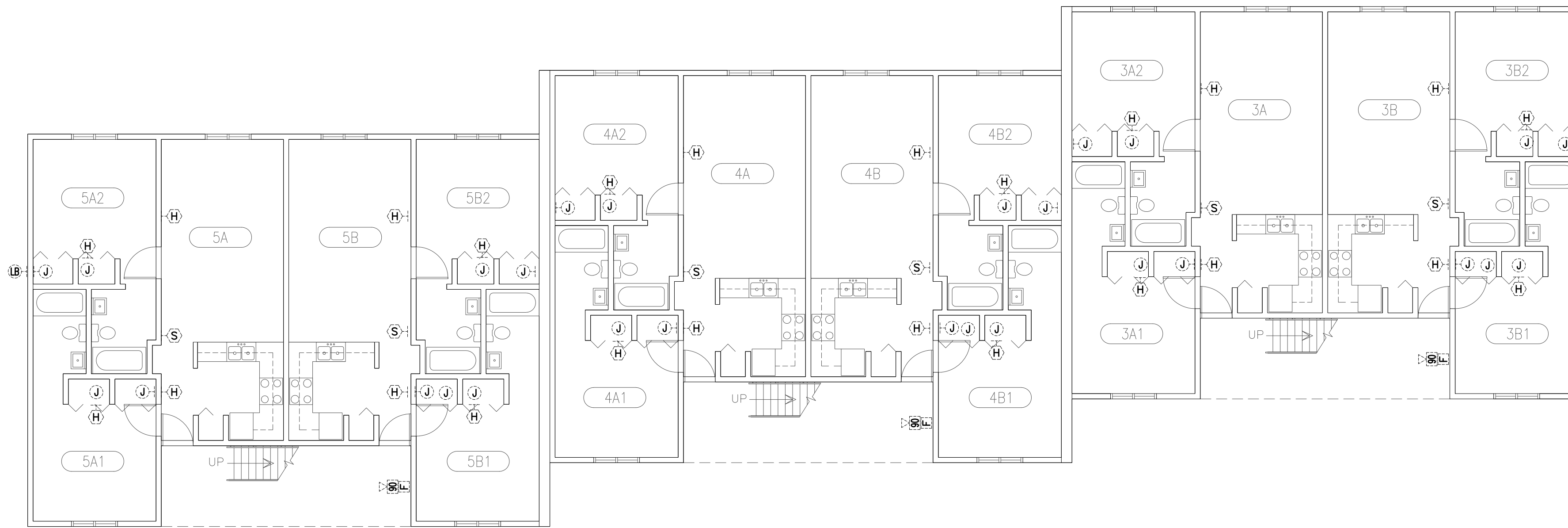

1 BUILDINGS 3, 4 & 5
FIRST FLOOR PLAN
SCALE: 1/8"=1'-0"

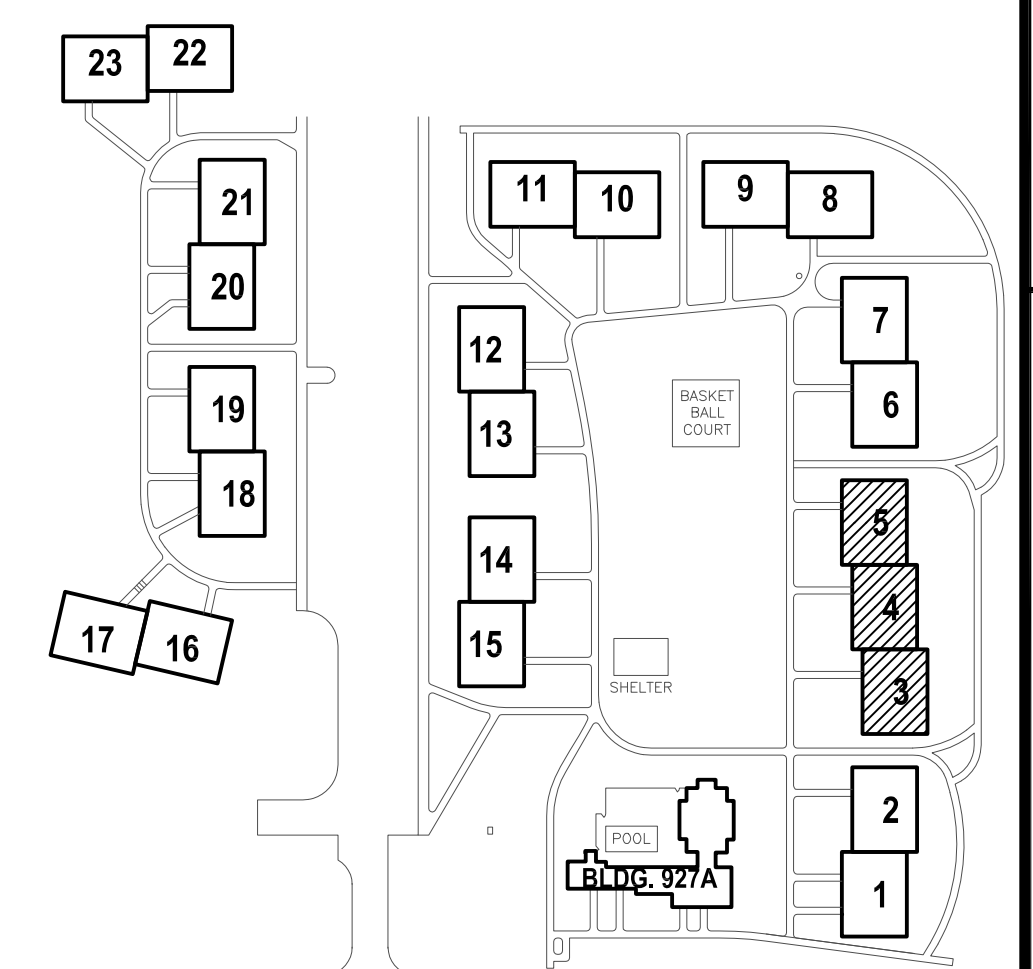

KEY PLAN
NOT TO SCALE

NO.	REVISION	DATE	BY
Δ			
Δ			
Δ			
Δ			

sims group
SIMS GROUP ENGINEERS, INC.
800 Columbian Drive, Suite 208
Irvine, South Carolina 29663
www.simsgrupos.com

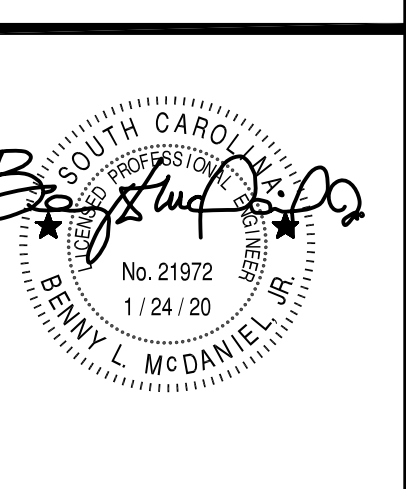
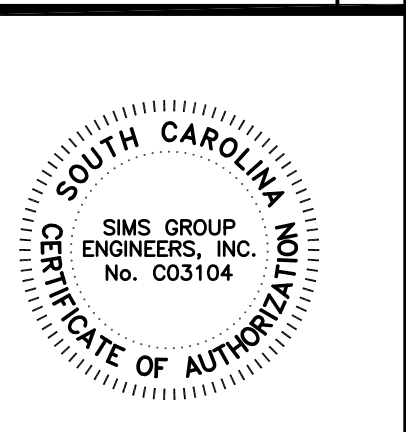

**RE-BID USCA PACER DOWNS FIRE
ALARM REPLACEMENT
PROJECT NUMBER FP00000284
TYPICAL BUILDING DEMOLITION FIRE ALARM PLAN**

DRAWN	JMO
CHECKED	BLM
SIMS PROJECT No.	C19035
DATE	01.24.20

E005

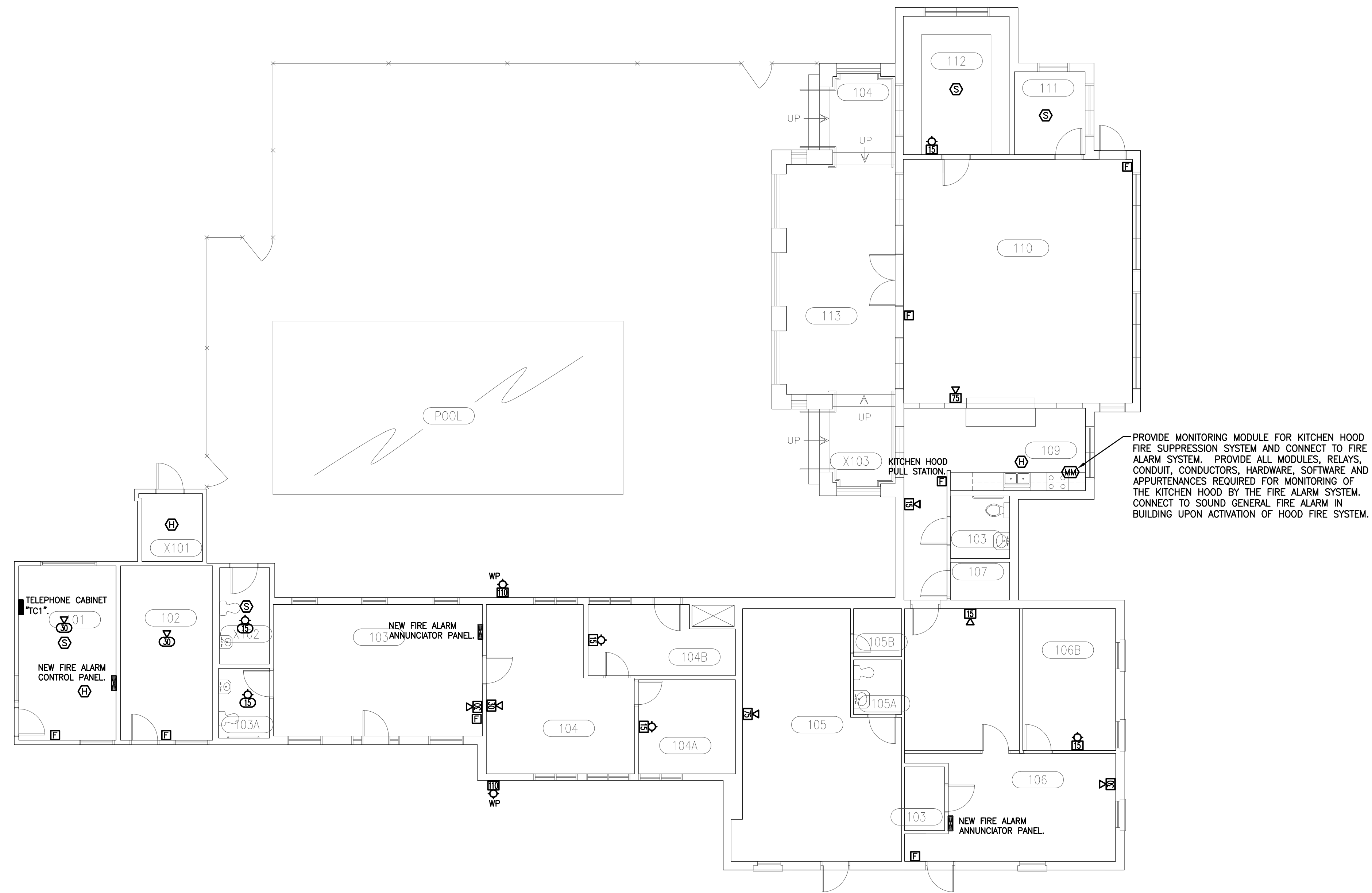

FIRE ALARM NOTES:

- ① PROVIDE SMOKE DETECTOR WITHIN THREE (3) FT. FROM THE BATHROOM DOOR WHEN THE BATHROOM CONTAINS A BATHTUB OR SHOWER PER 2015 IBC SECTION 907.2.11.4.
- ② CONTRACTOR IS RESPONSIBLE FOR REPAIRING, PATCHING OF DRYWALL AND PAINTING WHEN REMOVING OLD FIRE ALARM DEVICES AND INSTALLING NEW FIRE ALARM DEVICES.

1 FIRST FLOOR PLAN - 927A
SCALE: 1/8"=1'-0"

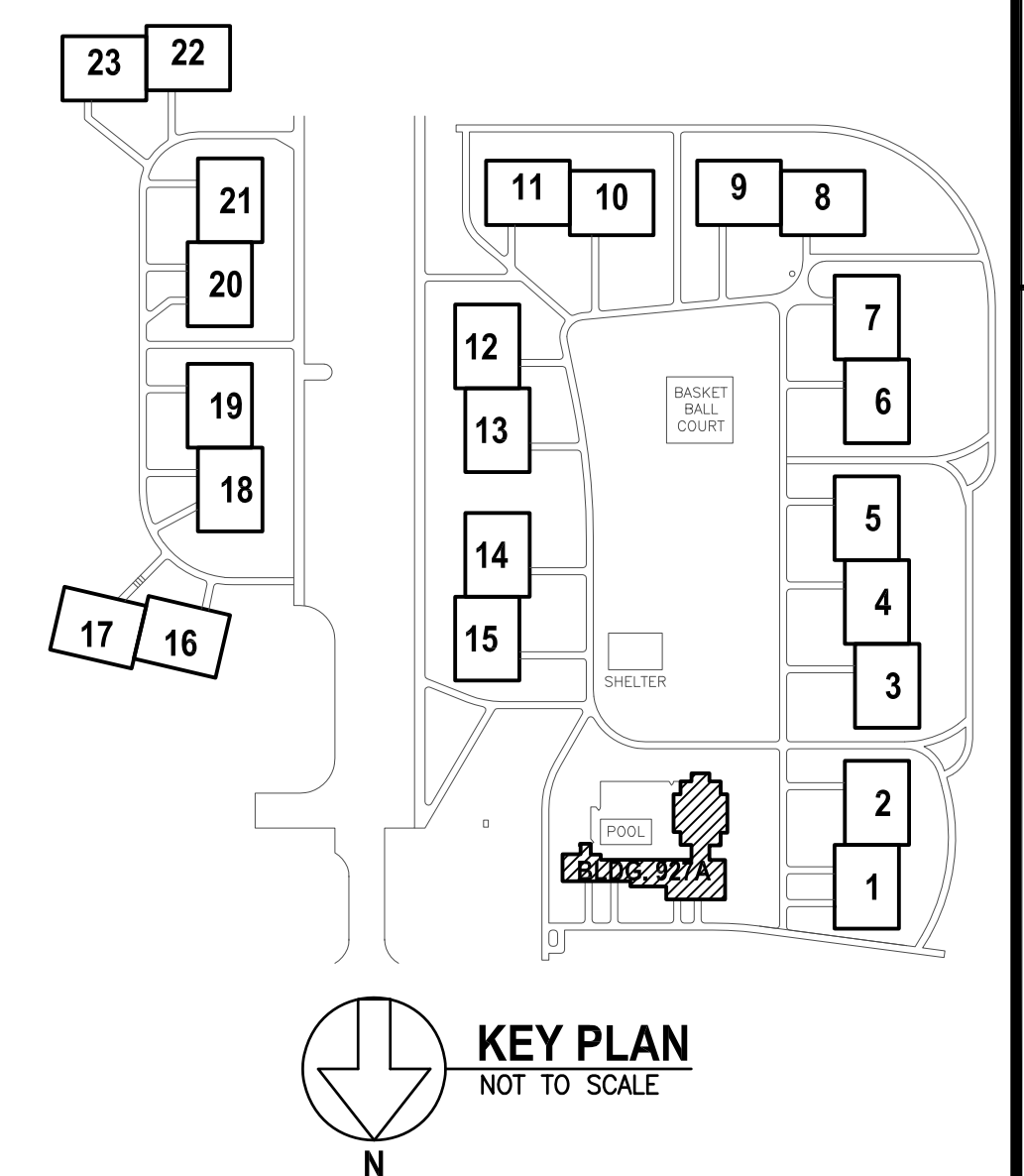

KEY PLAN
NOT TO SCALE

NO.	REVISION	DATE	BY
Δ			
Δ			
Δ			
Δ			

sims group
SIMS GROUP ENGINEERS, INC.
800 Columbiana Drive, Suite 208
Irvine, South Carolina 29663
www.simsgrupp.com

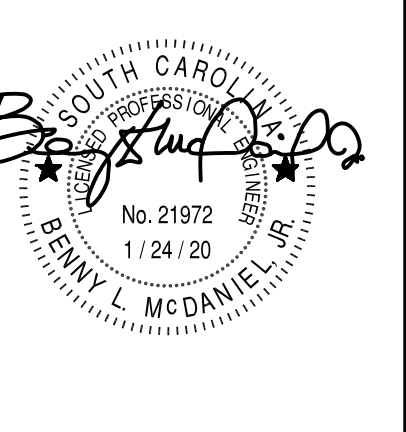
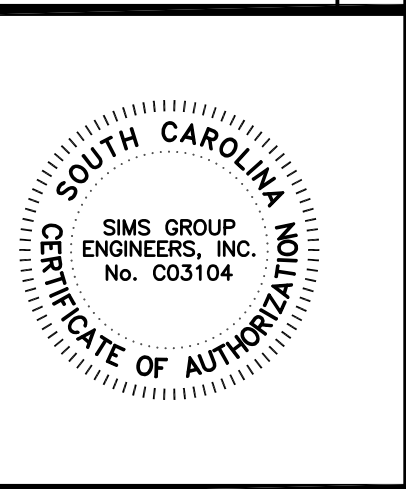

RE-BID USCA PACER DOWNS FIRE ALARM REPLACEMENT
PROJECT NUMBER FP00000284
TYPICAL BUILDING NEW FIRE ALARM PLAN

DRAWN	JMO
CHECKED	BLM
SIMS PROJECT No.	C19035
DATE	01.24.20

E501

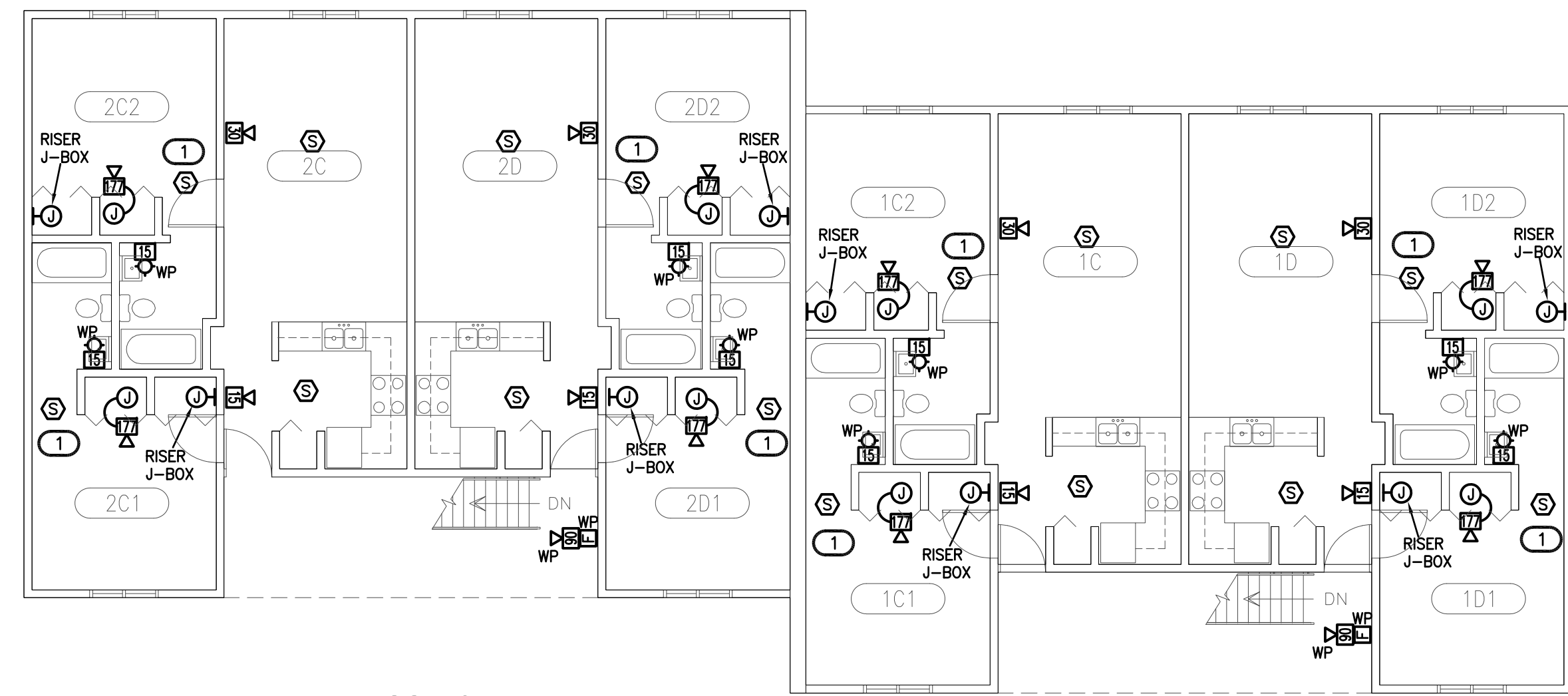

2 BUILDINGS 1 & 2 SECOND FLOOR PLAN
SCALE: 1/8"=1'-0"

***TYPICAL FOR ALL 8 UNIT APARTMENTS.

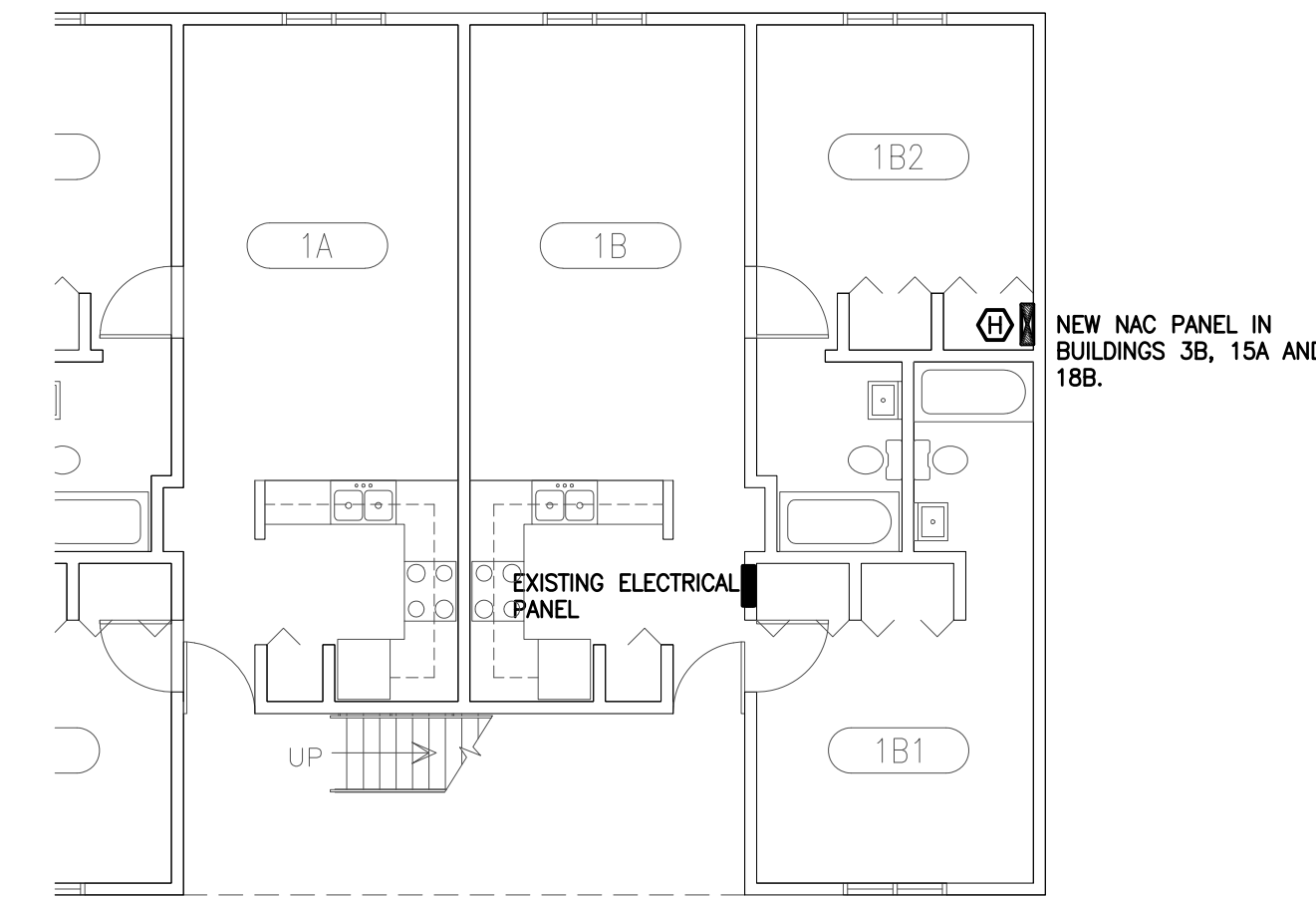

3 POWER PLAN TYPICAL OF ALL UNITS
SCALE: 1/8"=1'-0"

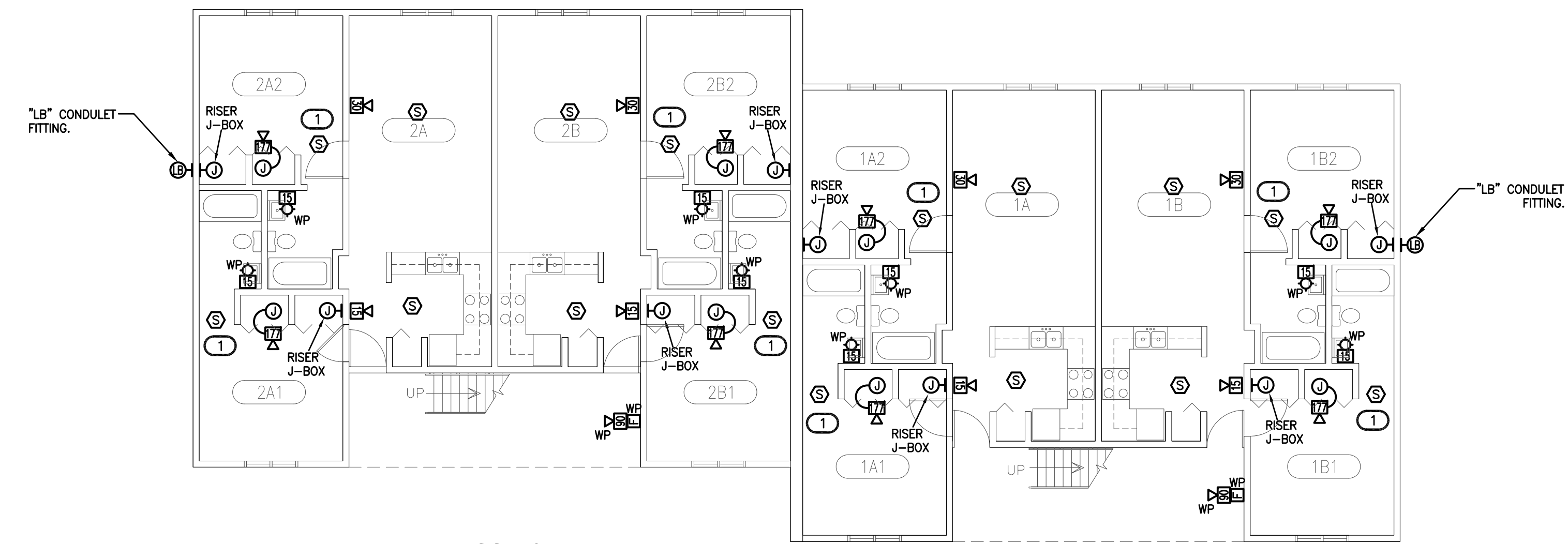

1 BUILDINGS 1 & 2 FIRST FLOOR PLAN
SCALE: 1/8"=1'-0"

***TYPICAL FOR ALL 8 UNIT APARTMENTS.

FIRE ALARM NOTES:

- 1 PROVIDE SMOKE DETECTOR WITHIN THREE (3) FT. FROM THE BATHROOM DOOR WHEN THE BATHROOM CONTAINS A BATHTUB OR SHOWER PER 2015 IBC SECTION 907.2.11.4.
- 2 CONTRACTOR IS RESPONSIBLE FOR REPAIRING, PATCHING OF DRYWALL AND PAINTING WHEN REMOVING OLD FIRE ALARM DEVICES AND INSTALLING NEW FIRE ALARM DEVICES.

FIRE ALARM DEVICES IN SLEEPING AREAS

GUEST ROOMS / SLEEPING AREAS SHOWN ON THIS DRAWING SHALL BE PROVIDED WITH LISTED LOW FREQUENCY AUDIBLE SOUNDERS WHICH MEET THE REQUIREMENT OF NFPA-72 FOR SLEEPING SPACES. ALL AUDIBLE SOUNDERS AND FIRE ALARM EQUIPMENT SHALL BE COMPATIBLE WITH THE NEW FIRE ALARM SYSTEM. CONTRACTOR MAY PROVIDE ADDRESSABLE HORN/STROBES, SMOKE DETECTORS WITH SOUNDER BASE, OR SOME COMBINATION THEREOF. COORDINATE WITH ELECTRICAL ENGINEER AND SUBMIT SHOP DRAWINGS FOR REVIEW AND APPROVAL.

UPON ACTIVATION OF THE ASSOCIATED SMOKE DETECTOR IN GUEST ROOM, ALL FIRE ALARM DEVICES IN GUESTROOMS SHALL ACTIVATE AND SEND TROUBLE SIGNAL TO REPORTING SERVICE. FIRE ALARM DEVICES WITHIN EACH GUEST ROOM SHALL BE INTERCONNECTED SO THAT ACTIVATION OF ANY SMOKE DETECTOR IN THE SPACE CAUSES ALL DEVICES IN THE SPACE TO ALARM.

FIRE ALARM DEVICES IN EACH GUEST ROOM IN ALARM SHALL SEND TROUBLE SIGNAL TO REPORTING SERVICE. EACH GUEST ROOM SHALL BE IDENTIFIED.

SMOKE DETECTORS IN COMMON SPACES AND CORRIDORS SHALL SOUND GENERAL FIRE ALARM AND SEND SIGNALS TO REPORTING SERVICE.

HORN / STROBE IN SPACE SHALL BE PROGRAMMED TO INITIATE UPON ACTIVATION OF SMOKE DETECTOR IN SPACE OR UPON ACTIVATION OF GENERAL FIRE ALARM.

PROVIDE PROGRAMMING OF FIRE ALARM DEVICES AND WHEN TO SOUND GENERAL FIRE ALARM STRICTLY IN ACCORDANCE WITH LOCAL FIRE MARSHAL AND USC STAFF PERSONNEL.

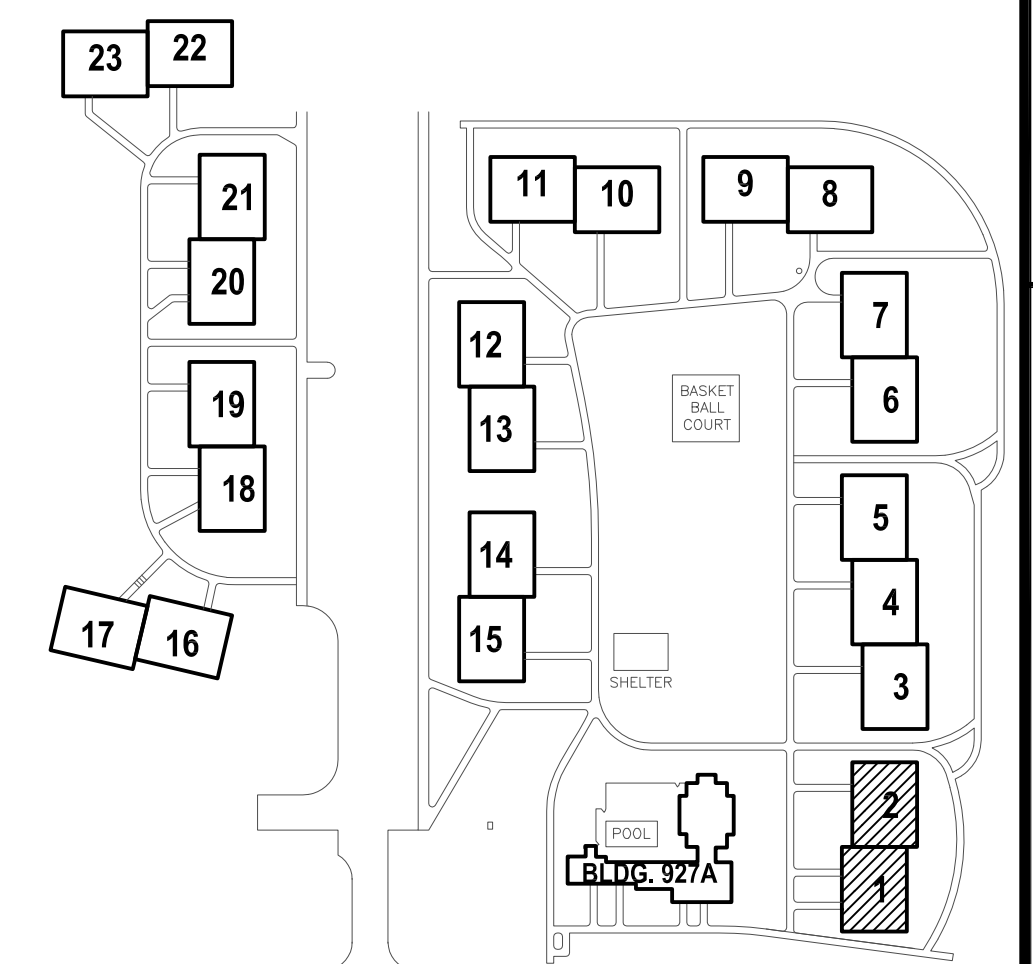

KEY PLAN
NOT TO SCALE

NO.	REVISION	DATE	BY
1			
2			
3			
4			
5			

BID SET

sims group
SIMS GROUP ENGINEERS, INC.
800 Columbian Drive, Suite 208
Irmo, South Carolina 29963
www.simgroupus.com

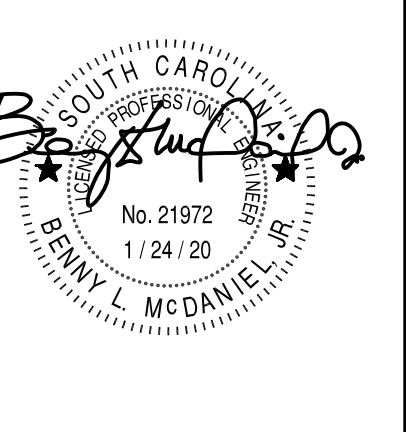
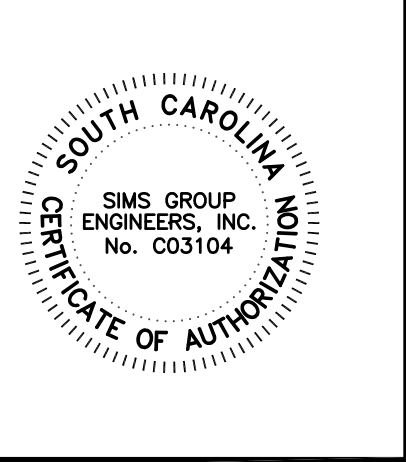

RE-BID USCA PACER DOWNS FIRE ALARM REPLACEMENT PROJECT NUMBER FP00000284 TYPICAL BUILDING NEW FIRE ALARM PLAN

DRAWN	JMO
CHECKED	BLM
SIMS PROJECT No.	C19035
DATE	01.24.20

E502
DRAWING No. 7 OF 10

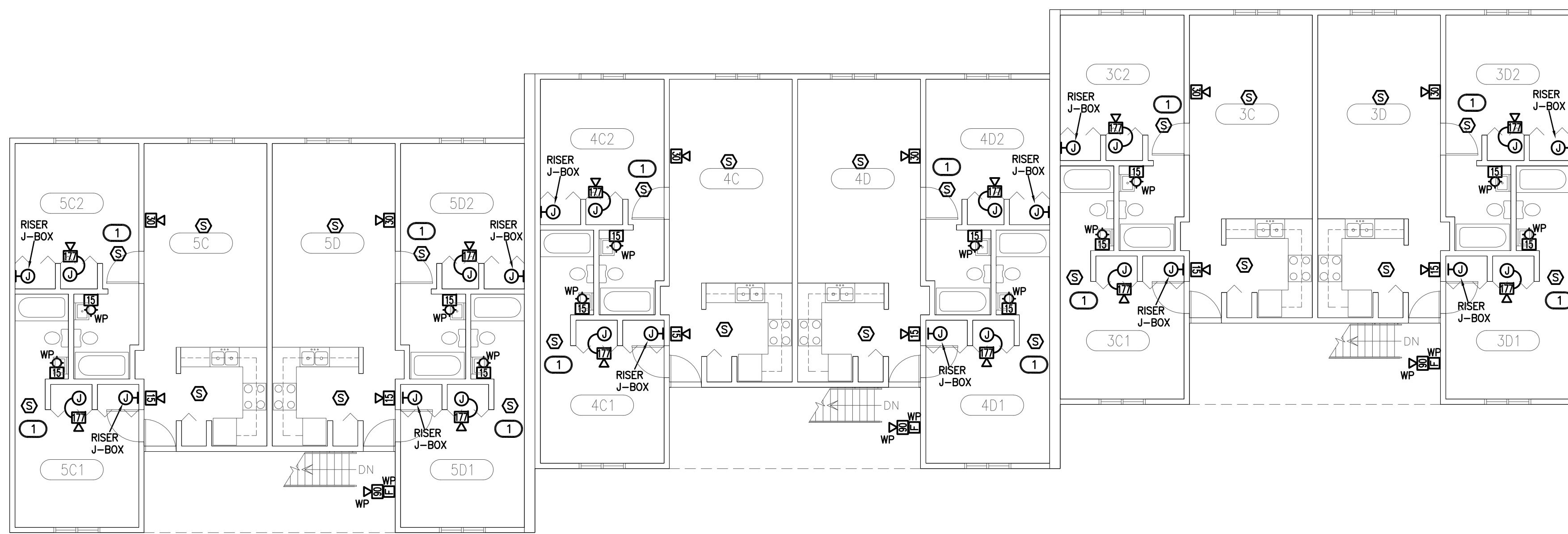

2 BUILDINGS 3, 4 & 5
SECOND FLOOR PLAN
SCALE: 1/8"=1'-0"

- FIRE ALARM NOTES:**
- 1 PROVIDE SMOKE DETECTOR WITHIN THREE (3) FT. FROM THE BATHROOM DOOR WHEN THE BATHROOM CONTAINS A BATHTUB OR SHOWER PER 2015 IBC SECTION 907.2.11.4.
 - 2 CONTRACTOR IS RESPONSIBLE FOR REPAIRING, PATCHING OF DRYWALL AND PAINTING WHEN REMOVING OLD FIRE ALARM DEVICES AND INSTALLING NEW FIRE ALARM DEVICES.

FIRE ALARM DEVICES IN SLEEPING AREAS

GUEST ROOMS / SLEEPING AREAS SHOWN ON THIS DRAWING SHALL BE PROVIDED WITH LISTED LOW FREQUENCY AUDIBLE SOUNDERS WHICH MEET THE REQUIREMENT OF NFPA-72 FOR SLEEPING SPACES. ALL AUDIBLE SOUNDERS AND FIRE ALARM EQUIPMENT SHALL BE COMPATIBLE WITH THE NEW FIRE ALARM SYSTEM. CONTRACTOR MAY PROVIDE ADDRESSABLE HORN/STROBES, SMOKE DETECTORS WITH SOUNDER BASE, OR SOME COMBINATION THEREOF. COORDINATE WITH ELECTRICAL ENGINEER AND SUBMIT SHOP DRAWINGS FOR REVIEW AND APPROVAL.

UPON ACTIVATION OF THE ASSOCIATED SMOKE DETECTOR IN GUEST ROOM, ALL FIRE ALARM DEVICES IN GUESTROOMS SHALL ACTIVATE AND SEND TROUBLE SIGNAL TO REPORTING SERVICE. FIRE ALARM DEVICES WITHIN EACH GUEST ROOM SHALL BE INTERCONNECTED SO THAT ACTIVATION OF ANY SMOKE DETECTOR IN THE SPACE CAUSES ALL DEVICES IN THE SPACE TO ALARM.

FIRE ALARM DEVICES IN EACH GUEST ROOM IN ALARM SHALL SEND TROUBLE SIGNAL TO REPORTING SERVICE. EACH GUEST ROOM SHALL BE IDENTIFIED.

SMOKE DETECTORS IN COMMON SPACES AND CORRIDORS SHALL SOUND GENERAL FIRE ALARM AND SEND SIGNALS TO REPORTING SERVICE.

HORN / STROBE IN SPACE SHALL BE PROGRAMMED TO INITIATE UPON ACTIVATION OF SMOKE DETECTOR IN SPACE OR UPON ACTIVATION OF GENERAL FIRE ALARM.

PROVIDE PROGRAMMING OF FIRE ALARM DEVICES AND WHEN TO SOUND GENERAL FIRE ALARM STRICTLY IN ACCORDANCE WITH LOCAL FIRE MARSHAL AND USC STAFF PERSONNEL.

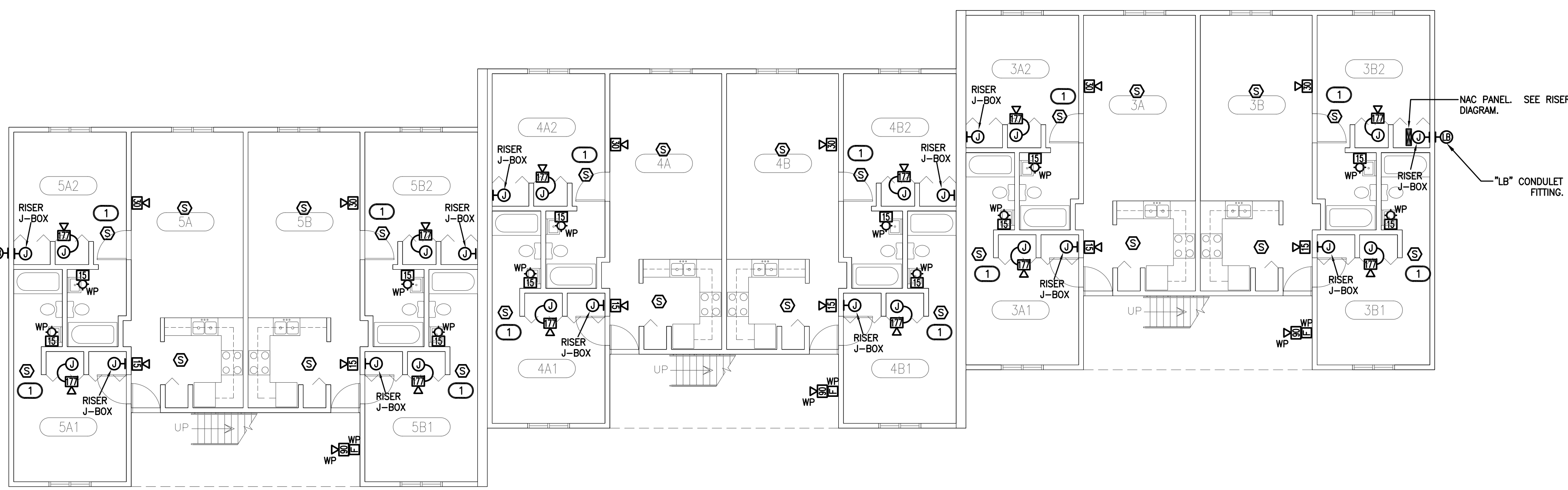

1 BUILDINGS 3, 4 & 5
FIRST FLOOR PLAN
SCALE: 1/8"=1'-0"

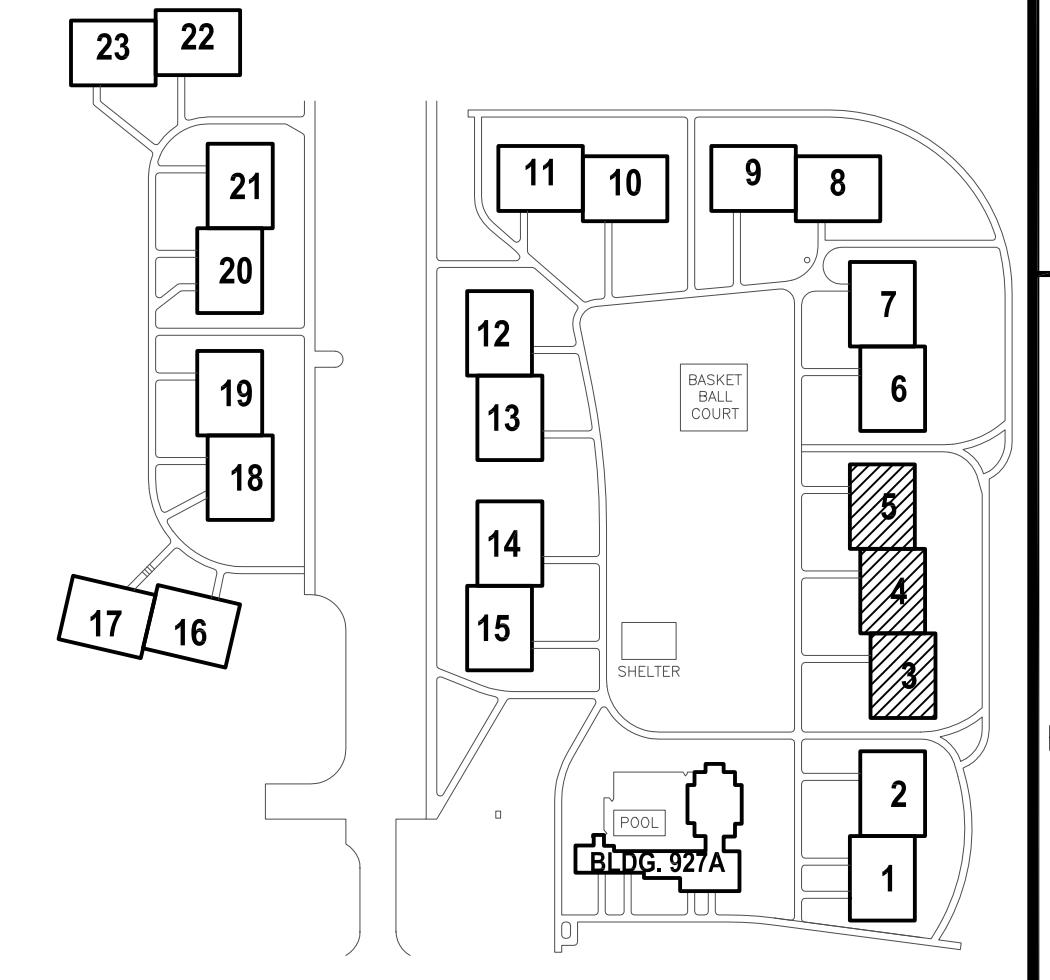

KEY PLAN
NOT TO SCALE

NO.	REVISION	DATE	BY
1			
2			
3			
4			
5			

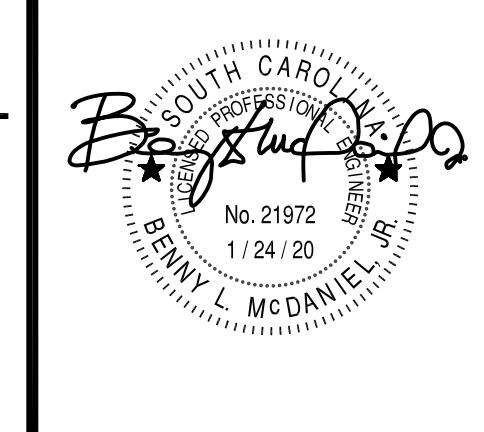
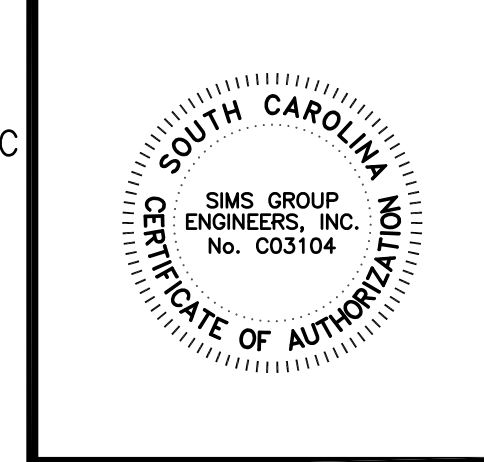

RE-BID USCA PACER DOWNS FIRE ALARM REPLACEMENT PROJECT NUMBER FP00000284

TYPICAL BUILDING NEW FIRE ALARM PLAN

DRAWN	JMO
CHECKED	BLM
SIMS PROJECT No.	C19035
DATE	01.24.20

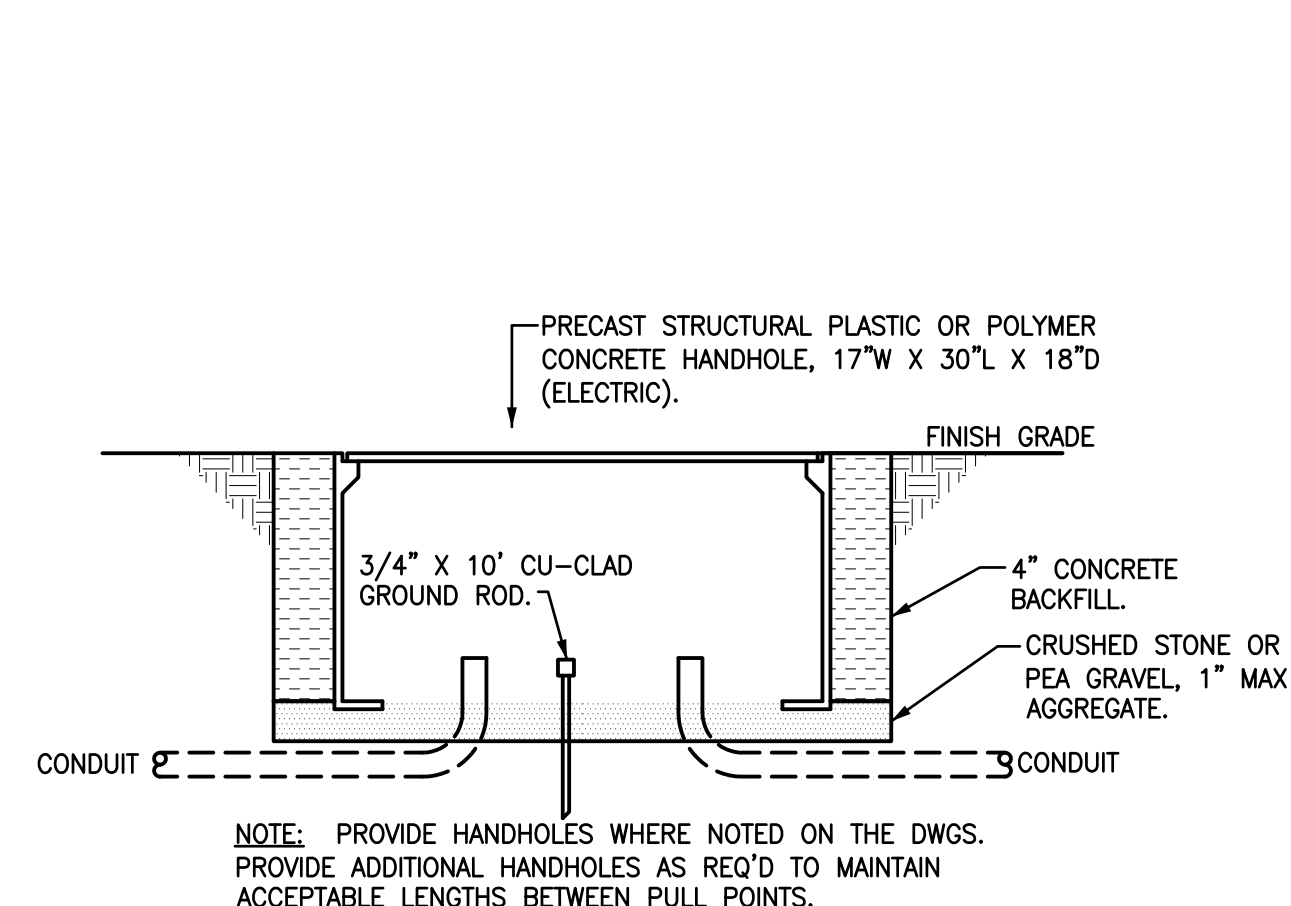

3 SECTION THRU HANDHOLE
NOT TO SCALE

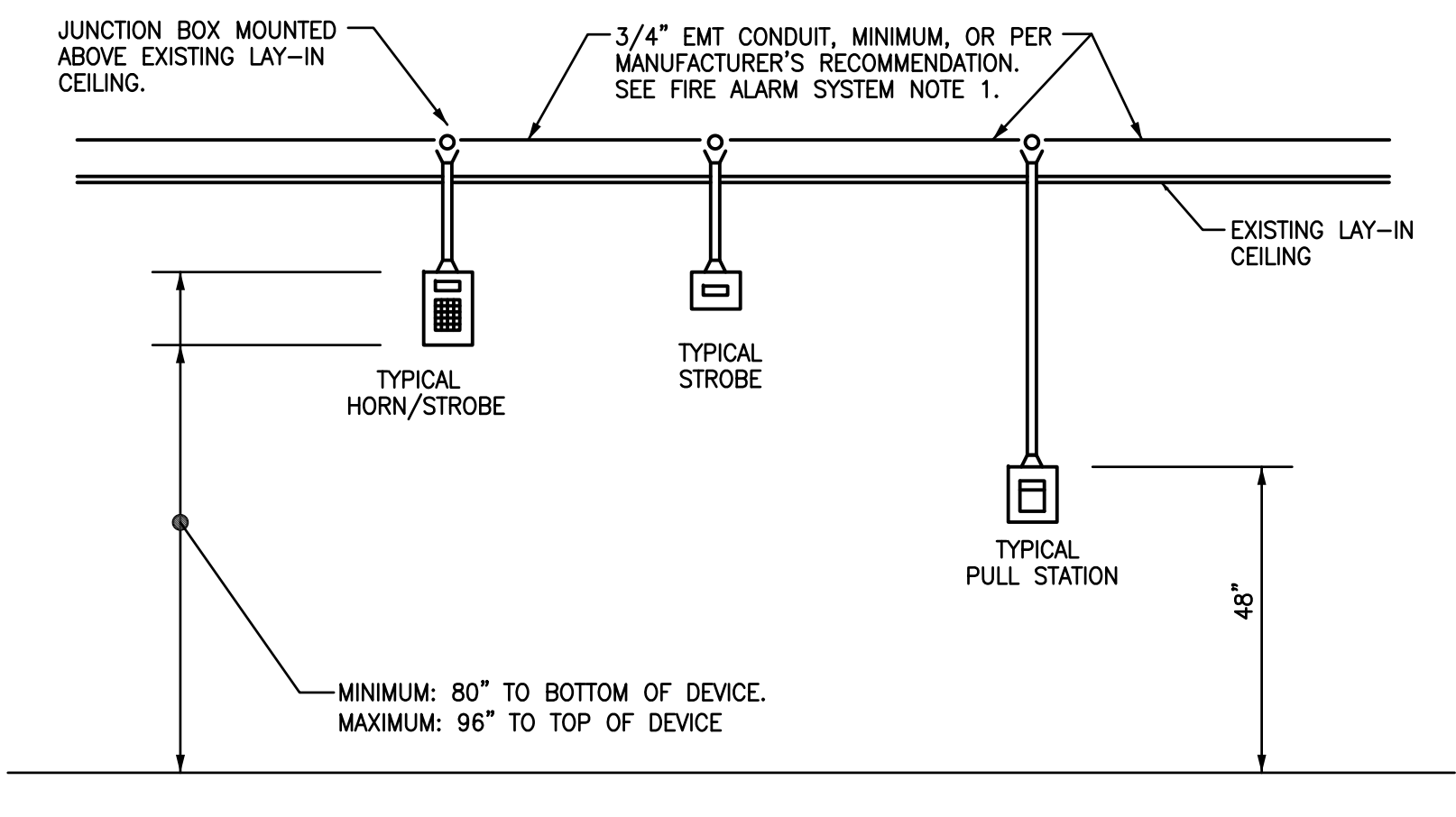

4 TYPICAL ELEVATIONS-LAY-IN CEILING
NOT TO SCALE

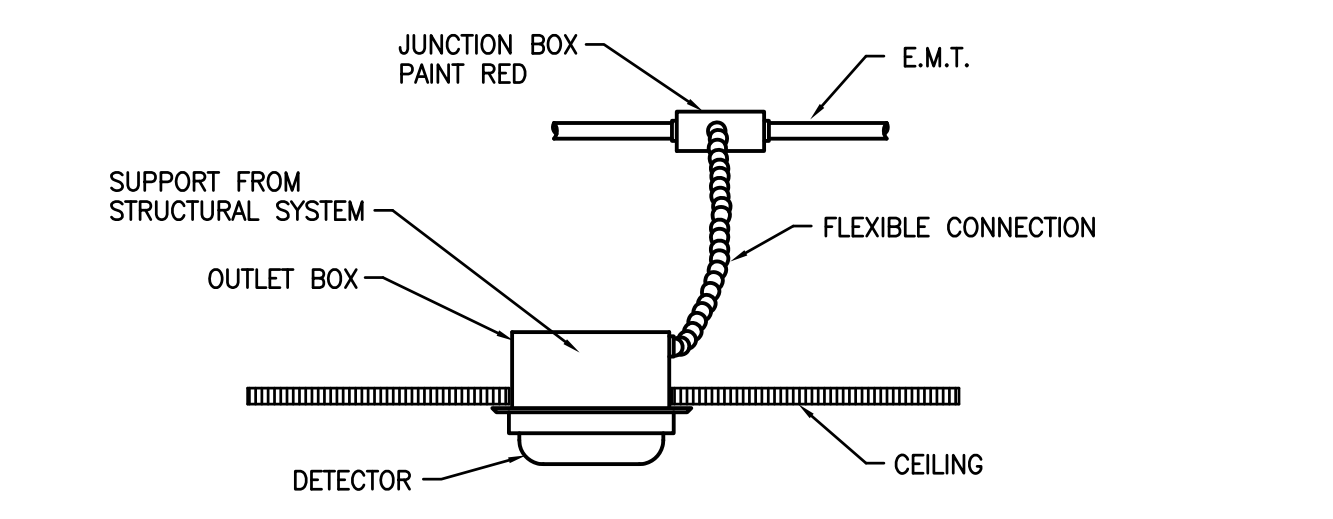

5 MULTI SENSOR DETECTOR INSTALLATION DETAIL
NOT TO SCALE

FIRE ALARM SYSTEM NOTES

- ALL FIRE ALARM SYSTEM WIRING SHALL BE RUN ABOVE GRADE IN WALLS AND ABOVE CEILING IN METAL RACEWAYS. RACEWAYS SHALL BE RUN CONCEALED. FIRE ALARM WIRING MAY NOT BE RUN UNDERGROUND OR IN SLAB UNLESS SPECIFICALLY NOTED OTHERWISE ON THE DRAWINGS.
- VERIFY WIRING REQUIREMENTS WITH EQUIPMENT MFR PRIOR TO ROUGH-IN AND INSTALL ACCORDINGLY. NOTIFICATION APPLIANCE CIRCUITS SHALL BE RUN AS REQ'D TO PROVIDE A 3-PULSE TEMPORAL AUDIBLE SIGNAL WITHOUT COMPROMISING THE OPERATION OF THE STROBES.
- PROVIDE SYNCHRONIZATION OF ALL STROBE LIGHTS.
- FIRE ALARM SYSTEM TO BE CLASS B SUPERVISED SYSTEM (STYLE B INITIATING DEVICE CIRCUITS, STYLE 4 SIGNALING LINE CIRCUITS, CLASS B NOTIFICATION APPLIANCE CIRCUITS). FURNISH & INSTALL END-OF-LINE RESISTORS WHERE REQUIRED.
- EQUIPMENT SUPPLIER SHALL SUBMIT SHOP DRAWINGS INDICATING EXACT ROUTING OF RACEWAYS AND NUMBER AND SIZE OF CONDUCTORS IN RACEWAYS FOR THE FIRE ALARM SYSTEM. THE ELECTRICAL CONTRACTOR SHALL USE THE REVIEWED DRAWING FOR ROUGH-IN OF FIRE ALARM SYSTEM RACEWAYS AND OUTLET BOXES.
- MULTI SENSOR DETECTORS SHALL BE LOCATED AS NEAR THE CENTER OF THE ROOM AS PRACTICAL. DO NOT LOCATE ANY DETECTOR WITHIN 3-FT. OF AN HVAC SUPPLY OR RETURN GRILLE. PROVIDE AUXILIARY CONTACT ON SMOKE DETECTORS LOCATED IN CORRIDORS AT SMOKE DOORS. WIRE MAGNETIC DOOR HOLDERS THRU AUXILIARY CONTACT TO RELEASE DOOR WHEN THOSE DETECTORS ARE ACTUATED.
- LOCATE MANUAL PULL STATIONS WITHIN 5'-0" OF THE EXIT DOOR PER NFPA AND IBC REQUIREMENTS. PROVIDE ANY SPECIAL ADAPTER PLATES OR COVER PLATES REQ'D TO MOUNT PULL STATIONS IN DOOR MULLIONS WHERE APPLICABLE AND PAINT EXPOSED SURFACES TO MATCH MULLION.
- EACH HORN/STROBE OR STROBE LOCATED AT THE END OF A CORRIDOR MUST BE WITHIN 15'-0" OF THE END WALL PER NFPA 72. HORN/STROBES MUST BE LOCATED TO COMPLY WITH TABLE 7.5.4.3.1(a) & TABLE 7.5.4.3.1(b) OF NFPA 72. DO NOT ADJUST LOCATIONS OF HORN/STROBES WITHOUT CONSULTING WITH THE ENGINEER AND OBTAINING WRITTEN PERMISSION.
- FIELD VERIFY LOCATION OF FIRE ALARM PANEL "FAC" AND/OR REMOTE FIRE ALARM ANNUNCIATOR "FAA" WITH OWNER AND AUTHORITY HAVING JURISDICTION PRIOR TO ROUGH-IN.
- IN ADDITION TO DETECTORS SHOWN, CONTRACTOR WILL BE REQUIRED TO FURNISH & INSTALL MULTI SENSOR DETECTORS IN ALL ROOMS WITH FIRE ALARM CONTROL PANELS, POWER SUPPLIES, AND POWER BOOSTERS. IN ADDITION TO 120V CIRCUITS SHOWN, CONTRACTOR SHALL BE REQUIRED TO FURNISH & INSTALL ANY 120V CIRCUITS NECESSARY TO PROVIDE A COMPLETE AND OPERABLE FIRE ALARM SYSTEM.
- ADDITIONAL FIRE ALARM DEVICES: THE ELECTRICAL CONTRACTOR AND FIRE ALARM SYSTEM INSTALLER SHALL FURNISH AND INSTALL ADDITIONAL FIRE ALARM DEVICES AT THE DISCRETION OF THE ARCHITECT/ENGINEER AND/OR THE AUTHORITY HAVING JURISDICTION IN THE FOLLOWING QUANTITIES:
 - (3) HORN/STROBE LIGHTS
 - (3) STROBE LIGHTS
 - (2) DUCT MOUNTED SMOKE DETECTORS
 - (2) MANUAL PULL STATIONS
 - (3) CEILING MOUNTED MULTI SENSOR DETECTORS
- INCLUDE COMPLETE COSTS TO FURNISH AND INSTALL THE ABOVE ADDITIONAL DEVICES IN BASE BID, INCLUDING ALL CONDUIT, OUTLET BOXES, 120V POWER, WIRING, SAMPLING TUBES AND SYSTEM PROGRAMMING. ANY DEVICES NOT USED SHALL BE TURNED OVER TO THE OWNER AS SPARE DEVICES AT THE END OF THE PROJECT.
- USE OWNER'S ACTUAL PLACARDED ROOM NAMES FOR FINAL PROGRAMMING OF THE FIRE ALARM SYSTEM. INDICATE ANY DISCREPANCIES WITH DRAWING ROOM NAMES OR NUMBERS ON AS-BUILT MARK-UPS.
- THE CONTRACTOR SHALL PROVIDE THE REQUIRED NUMBER OF POWER EXTENDER PANELS TO SUPPORT NOTIFICATION DEVICES. EXTENDER PANELS MAY BE STACKED A MAXIMUM OF TWO PANELS VERTICALLY.
- BACK BOXES FOR ALL CEILING FIRE ALARM DEVICES SHALL BE FLUSH MOUNTED WHERE CONDUIT IS ROUTED ABOVE FINISHED CEILING.
- EXTERIOR DEVICES SHALL BE EQUIPPED WITH WEATHERPROOF OPTIONS AS RECOMMENDED BY MANUFACTURER.

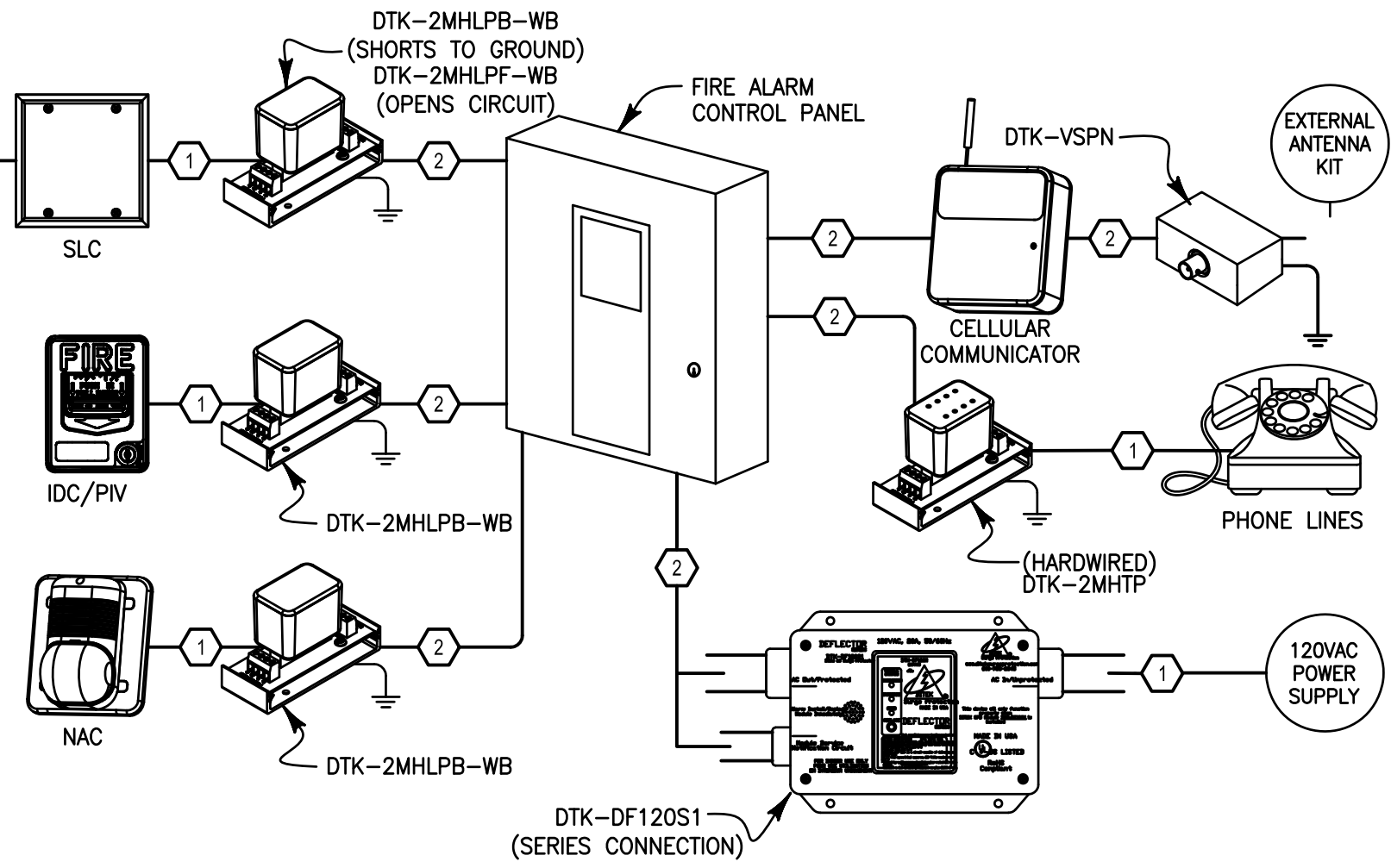
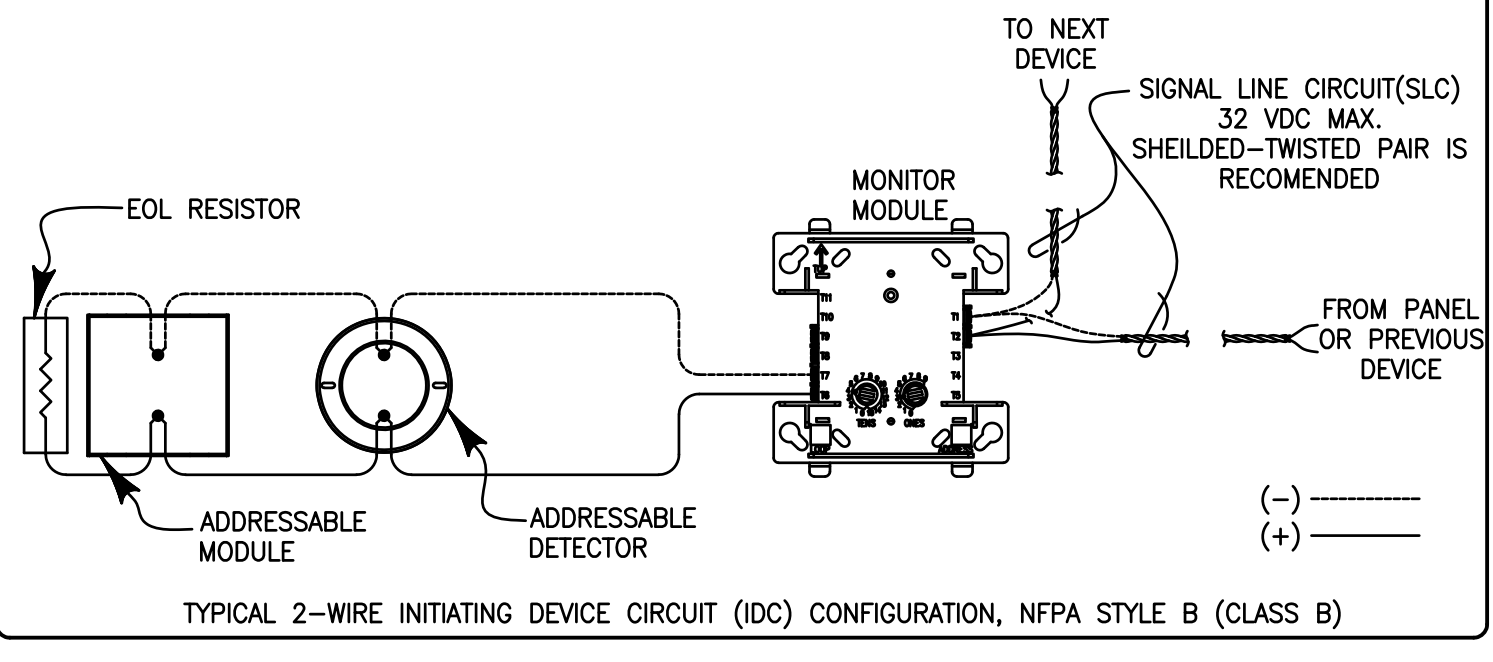
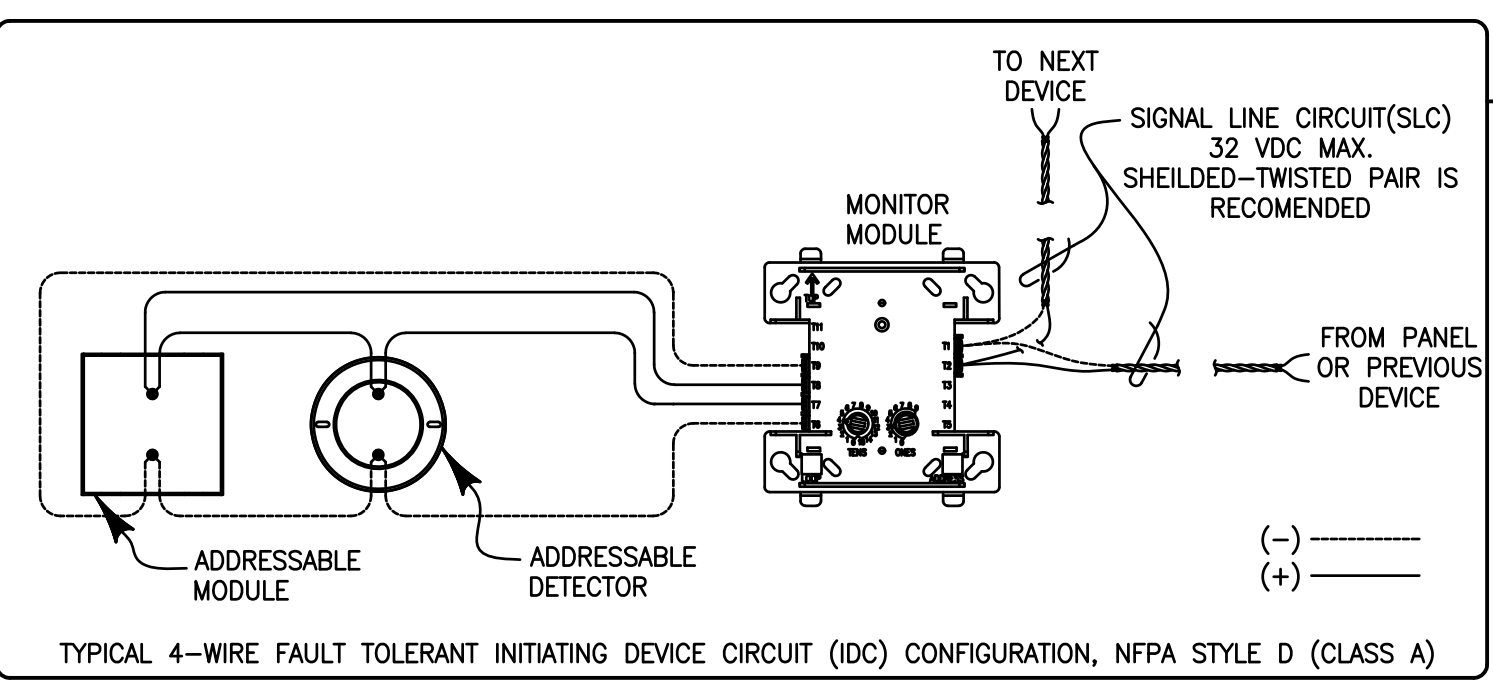
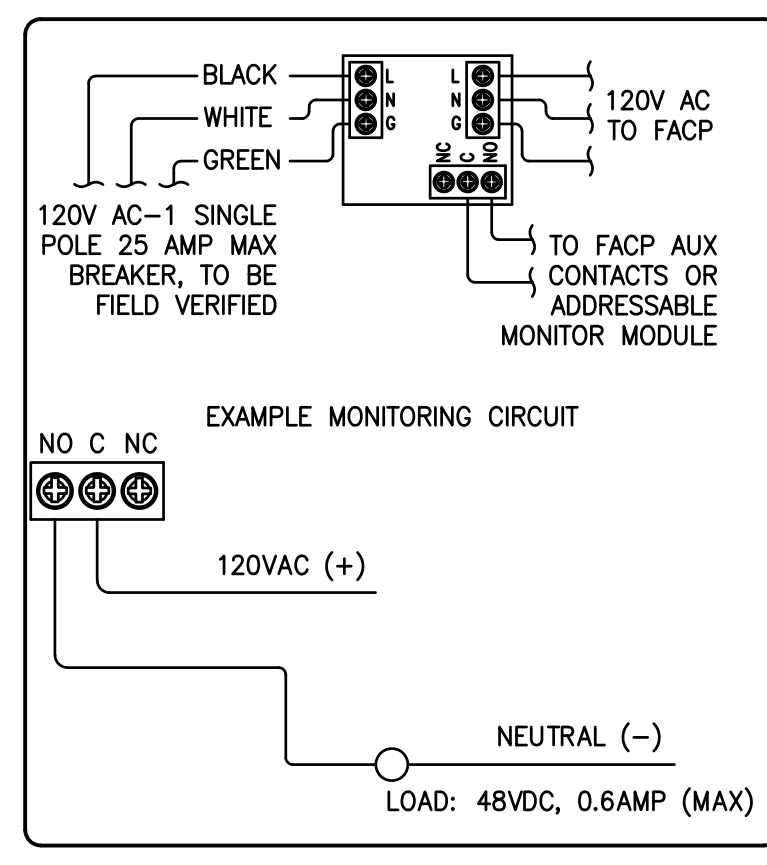

KEY NOTES:

- HIGH SURGE RISK CONNECTION, TYPICAL.
- PROTECTED COPPER CONNECTION, TYPICAL. MINIMUM 3' TO PROTECTED EQUIPMENT.

SIGNAL LINE CIRCUIT (SLC) NOTES:

- ANY NUMBER OF UL LISTED CONTACT CLOSURE DEVICES MAY BE USED. DO NOT MIX FIRE ALARM INITIATING, SUPERVISORY, OR SECURITY DEVICES ON THE SAME MODULE.
- INSTALL CONTACT CLOSURE DEVICES PER MANUFACTURER INSTALLATION INSTRUCTIONS.
- ALL WIRING SHOWN IS SUPERVISED AND POWER LIMITED.
- CONNECT MODULES TO COMPATIBLE CONTROL PANELS ONLY.

2 FIRE ALARM SURGE PROTECTION ONE-LINE DIAGRAM
NOT TO SCALE

FIRE ALARM SYMBOLS

■ FAC	EXISTING AND NEW FIRE ALARM CONTROL PANEL
■ FAA	EXISTING AND NEW FIRE ALARM ANNUNCIATOR
■	TELEPHONE CABINET "TC1"
■	MANUAL PULL STATION. 48" AFF.
■	WALL MOUNTED HORN WITH STROBE LIGHT, CANDELA RATING AS NOTED. MOUNT BETWEEN 80" AND 96" AFF. PER NFPA 72 AND ADA REQUIREMENTS.
■	CEILING MOUNTED FIRE ALARM HORN WITH STROBE LIGHT, CANDELA RATING AS NOTED.
■	WALL MOUNTED STROBE LIGHT, CANDELA RATING AS NOTED. MOUNT BETWEEN 80" AND 96" AFF. PER NFPA 72 AND ADA REQUIREMENTS.
■	CEILING MOUNTED FIRE ALARM STROBE LIGHT, CANDELA RATING AS NOTED.
■	MULTI SENSOR (PHOTOELECTRIC, THERMAL) DETECTOR, CEILING MOUNTED, UNLESS NOTED.
WP	WEATHERPROOF DEVICE. PROVIDE BACKBOX AND COVER U.L. LISTED AS WEATHERPROOF.
⊖	WALL MOUNTED HORN SOUNDER, TO BE DEMOLISHED.
⊖	120V SMOKE DETECTOR TO BE DEMOLISHED. TURN OVER TO OWNER.
⊖	CEILING MOUNTED SMOKE DETECTOR. PROVIDE VANDAL RESISTANT HEAD.
⊕ ⊖	EXISTING AND NEW EMT RISER JUNCTION BOX.
⊖ ⊕	EXISTING AND NEW "LB" CONDULET FITTING.

FIRE ALARM SYMBOL SCHEDULE NOTES:

- WALL MOUNTED NOTIFICATION DEVICES SHALL BE LOCATED AT UNIFORM HEIGHT ABOVE FINISHED FLOOR WHERE CEILING HEIGHTS ALLOW.

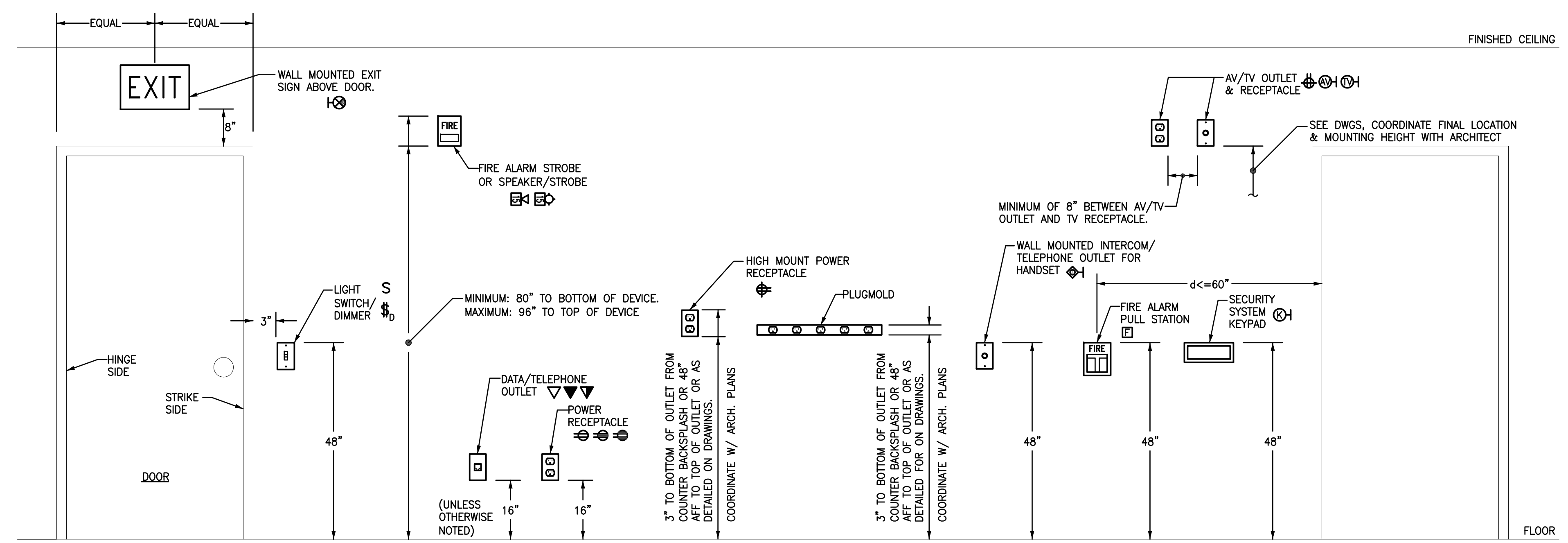

1 TYPICAL MOUNTING HEIGHTS FOR WALL MOUNTED DEVICES
NOT TO SCALE

NO.	REVISION	DATE	BY

BID SET

sims group

SIMS GROUP ENGINEERS, INC.
800 Columbia Drive, Suite 208
Irvine, South Carolina 29633
www.simgroupus.com

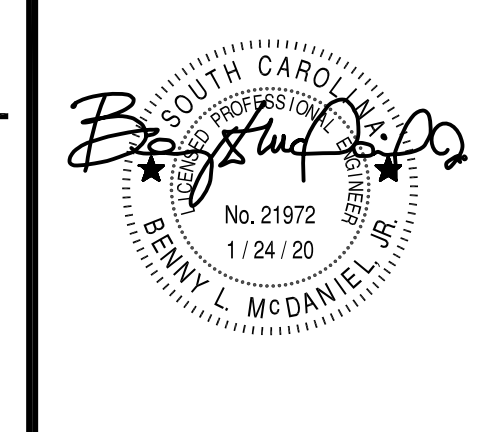
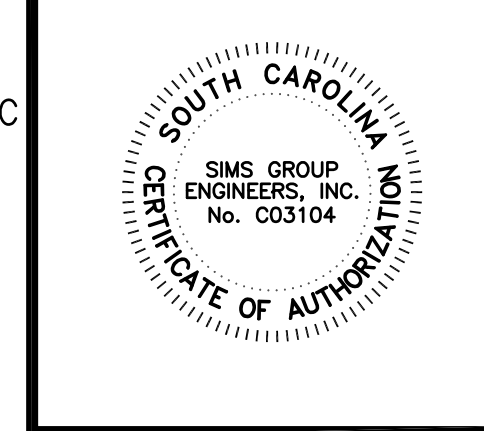

RE-BID USCA PACER DOWNS FIRE ALARM REPLACEMENT
PROJECT NUMBER FP00000284
FIRE ALARM RISER AND DETAILS

DRAWN	JMO
CHECKED	BLM
DATE	SIMS PROJECT No. C19035
01.24.20	

FIRE ALARM RISER KEYNOTES:

- (A) CONNECT TO THE EXISTING DEDICATED 20A CIRCUIT BREAKER IN EXISTING 120V PANEL. CONDUCTORS PER N.E.C. AND DRAWINGS. PROVIDE LOCK-OUT HASP FOR BREAKER AND PAINT CIRCUIT BREAKER HANDLE RED.
- (B) PROVIDE DACT AT NEW FIRE ALARM CONTROL PANEL. VERIFY NORMAL OPERATION OF TWO RJ-31X TELEPHONE JACKS AT FAC FOR REMOTE REPORTING CONNECTED TO TWO TELEPHONE LINES (ONE PRIMARY, ONE BACKUP) COORDINATE WITH OWNER'S IT DIRECTOR FOR TELEPHONE LINE WORK.
- (C) WHERE ALLOWED BY THE LOCAL FIRE MARSHAL, PROVIDE AN IPDACT WITH GSM(CELL) BACKUP. PRIOR TO INSTALLATION, COORDINATE WITH THE OWNER TO OBTAIN APPROVAL FROM THE LOCAL FIRE MARSHAL FOR THE IPDACT USE. PROVIDE IPDACT, HONEYWELL IPGSM-4G OR EQUIVALENT IPDACT. COORDINATE WITH THE OWNER'S IT DIRECTOR FOR IP NETWORK AND CELL PHONE CONNECTIONS. WIRE PER MANUFACTURER'S INSTRUCTIONS FOR IP PRIMARY/CELLULAR BACKUP OPERATION. RUN 3/4" EMPTY CONDUIT BETWEEN FAC & IPDACT AND FROM IPDACT TO ABOVE LAY-IN CEILING.
- (D) FIRE ALARM CONDUITS, SIGNAL CABLE AND WIRING SHALL BE RUN CONCEALED WHERE POSSIBLE.

FIRE ALARM RISER GENERAL NOTES:

- 1. ALL RISER CONDUIT SHALL BE MINIMUM 1" OR LARGER AS REQUIRED.
- 2. ALL DEVICE CIRCUIT CONDUIT RUNS SHALL BE 3/4" MINIMUM OR LARGER AS REQUIRED.
- 3. POWER EXTENDER PANELS "PPE": PROVIDE QUANTITY OF PPE PANELS AS REQUIRED FOR ACTUAL LOADS. LOCATE AS REQUIRED FOR COVERAGE OF THE BUILDING. PROVIDE NUMBER OF CIRCUITS AS REQUIRED BY LOADS TO 120V PANELS INDICATED AND SHOW LOCATIONS ON FIRE ALARM SHOP DRAWINGS.
- 4. FIRESTOP ALL THROUGH-WALL AND ALL THROUGH-FLOOR PENETRATIONS PER ASTM AND UL 1479, LATEST EDITION AT PROJECT BIDDING. PROVIDE ASSEMBLIES AS REQUIRED AS LISTED IN UL FIRE RESISTANCE DIRECTORY, LATEST EDITION.

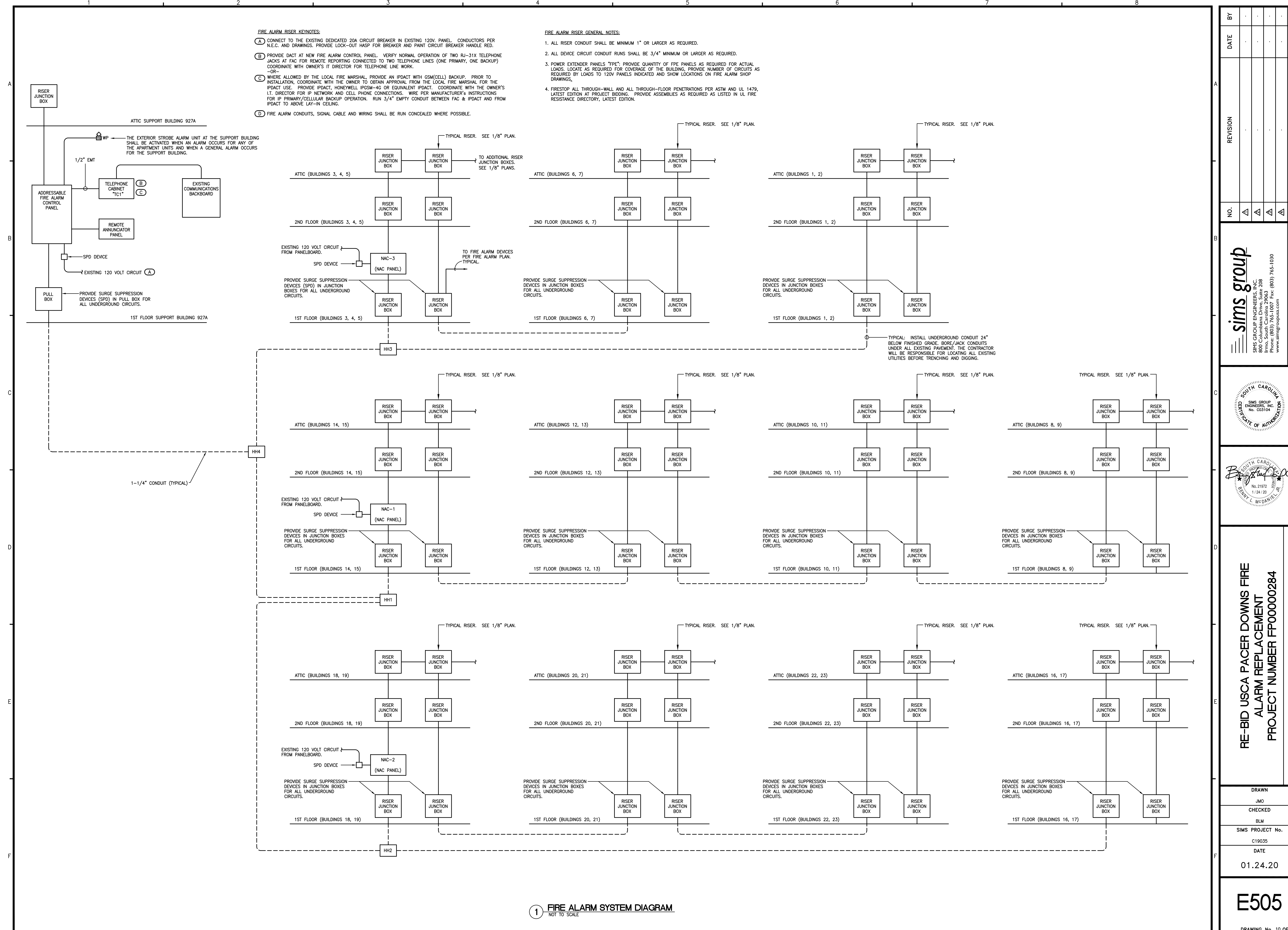

1 FIRE ALARM SYSTEM DIAGRAM
NOT TO SCALE

NO.	REVISION	DATE	BY
1			
2			
3			
4			
5			
6			
7			
8			

sims group
 SIMS GROUP ENGINEERS, INC.
 800 Columbian Drive, Suite 208
 Ima, South Carolina 29663
 www.simsgrupos.com

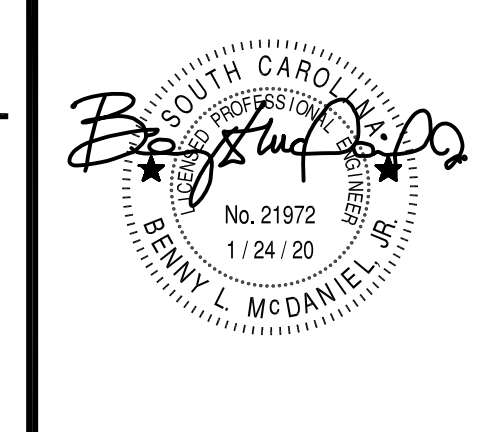
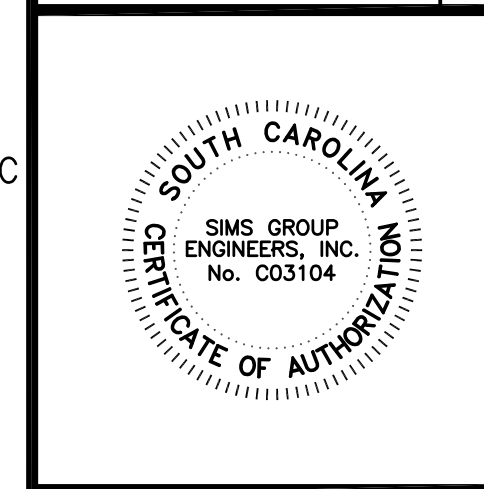

RE-BID USCA PACER DOWNS FIRE ALARM REPLACEMENT PROJECT NUMBER FP00000284
FIRE ALARM SYSTEM DIAGRAM

DRAWN	JMO
CHECKED	BLM
SIMS PROJECT No.	C19035
DATE	01.24.20